



CASE HISTORIES

Supplement No. 12
December, 1972

Companion journal to the
FLYING SAUCER REVIEW

Editor CHARLES BOWEN
Assistant Editor EILEEN BUCKLE
Consultants
GORDON CREIGHTON,
MA, FRAI, FRGS, FRAS
C. MAXWELL CADE,
AInstP, FRAS, AFRAeS,
CEng, FIEE, FIERE
BERNARD E. FINCH,
MRCS, LRCP, DCh, FBIS
CHARLES H. GIBBS-SMITH,
MA, FMA, Hon Companion
RAeS, FRSA
R. H. B. WINDER,
BSc, CEng, FIMechE
PERCY HENNEL
FIBP
Overseas
AIMÉ MICHEL
BERTHOLD E. SCHWARZ,
MD
Artwork
TERENCE COLLINS

CONTENTS

A Possible Landing at Matadepera	<i>José Maria Casas-Huguet</i>	1
UFO Landing Reported in Yugoslavia	<i>Milos Krmelj</i>	.. 4
UFO Photographed over Okinawa	<i>Jun-Ichi Takanashi</i>	.. 6
A French Landing in 1944	<i>F. Lagarde</i> 8
Preliminary Catalogue of Type 1 Cases in Argentina	<i>Oscar A. Uriondo</i> 9
UFO Occupant at Riachuelo, Chile	 12
Readers' Reports	 13
The Investigations of General Uchoa in Brazil—Part 1	<i>Gordon Creighton</i> 15
The Sighting at Ghost Pine Mine	<i>W. K. Allan</i> 16

1972

© Flying Saucer Review
Case Histories

Contributions appearing in this magazine do not necessarily reflect its policy and are published without prejudice

By Annual Subscription with effect from Supplement 11, U.K. and overseas £1.44 or U.S.A. and Canada \$3.80 (bank exchange commission on dollar cheques is catered for in this amount) or foreign currency equivalents. These amounts include postage by surface mail. Airmail per annum extra for U.S.A., Canada, S. Africa, Argentina, Brazil, etc., £1.10 (\$2.75); Australia, New Zealand, etc., £1.40; Middle East £0.80. Single copies 24p each (65c each)

Please address all letters to: *The Editor, FSR Case Histories, 21 Cecil Court, Charing Cross Road, London WC2N 4HB, England*

Subscriptions (payable to "FSR Publications Ltd.") to: *21 Cecil Court, Charing Cross Road, London WC2N 4HB, England*
Telephone: 01-639 0784

FLYING
SAUCER
REVIEW



CASE HISTORIES

TWENTY-FOUR PENCE

SUPPLEMENT 12

DECEMBER 1972

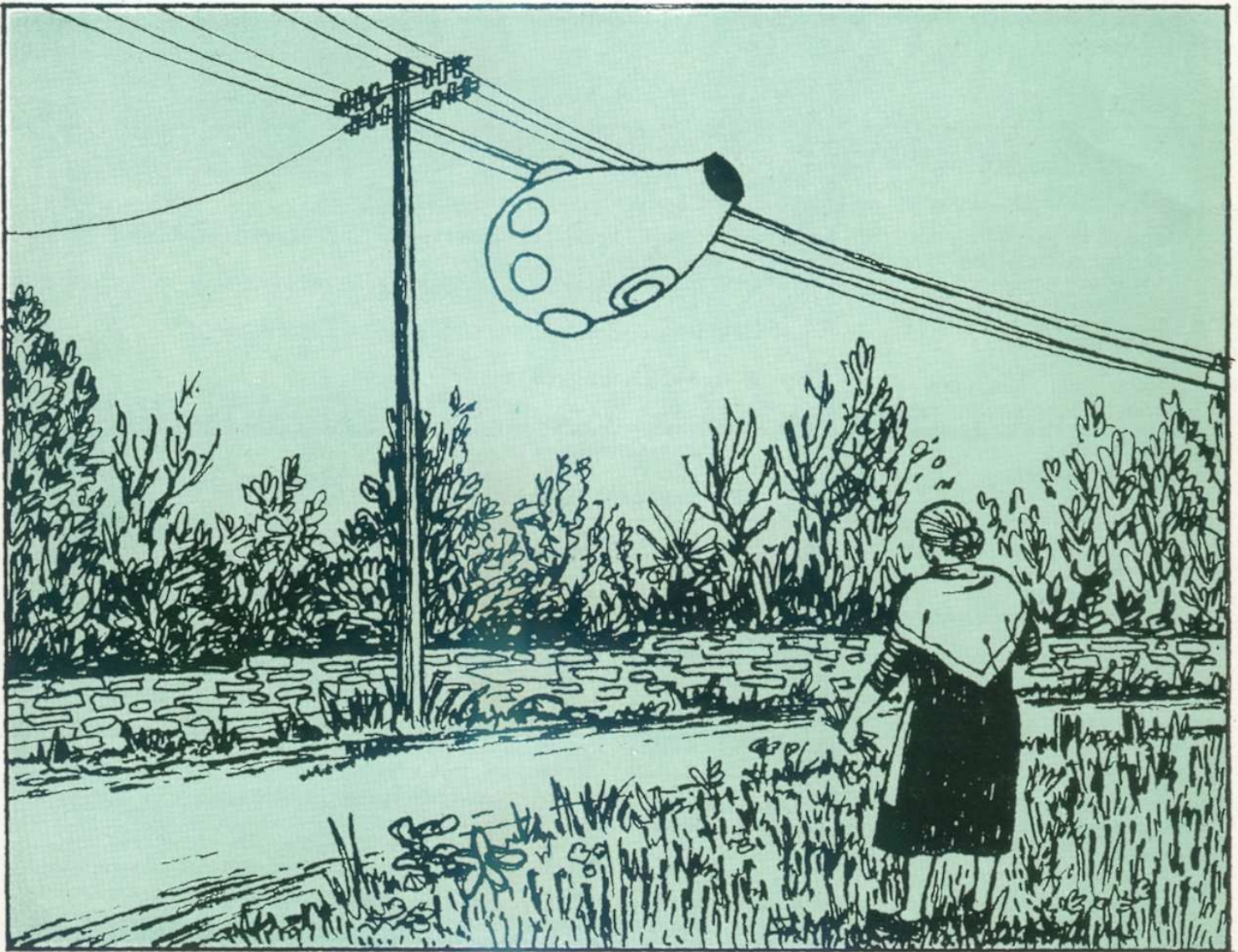

POSSIBLE LANDING AT MATADEPERA

A recent report from Spain

see page 1

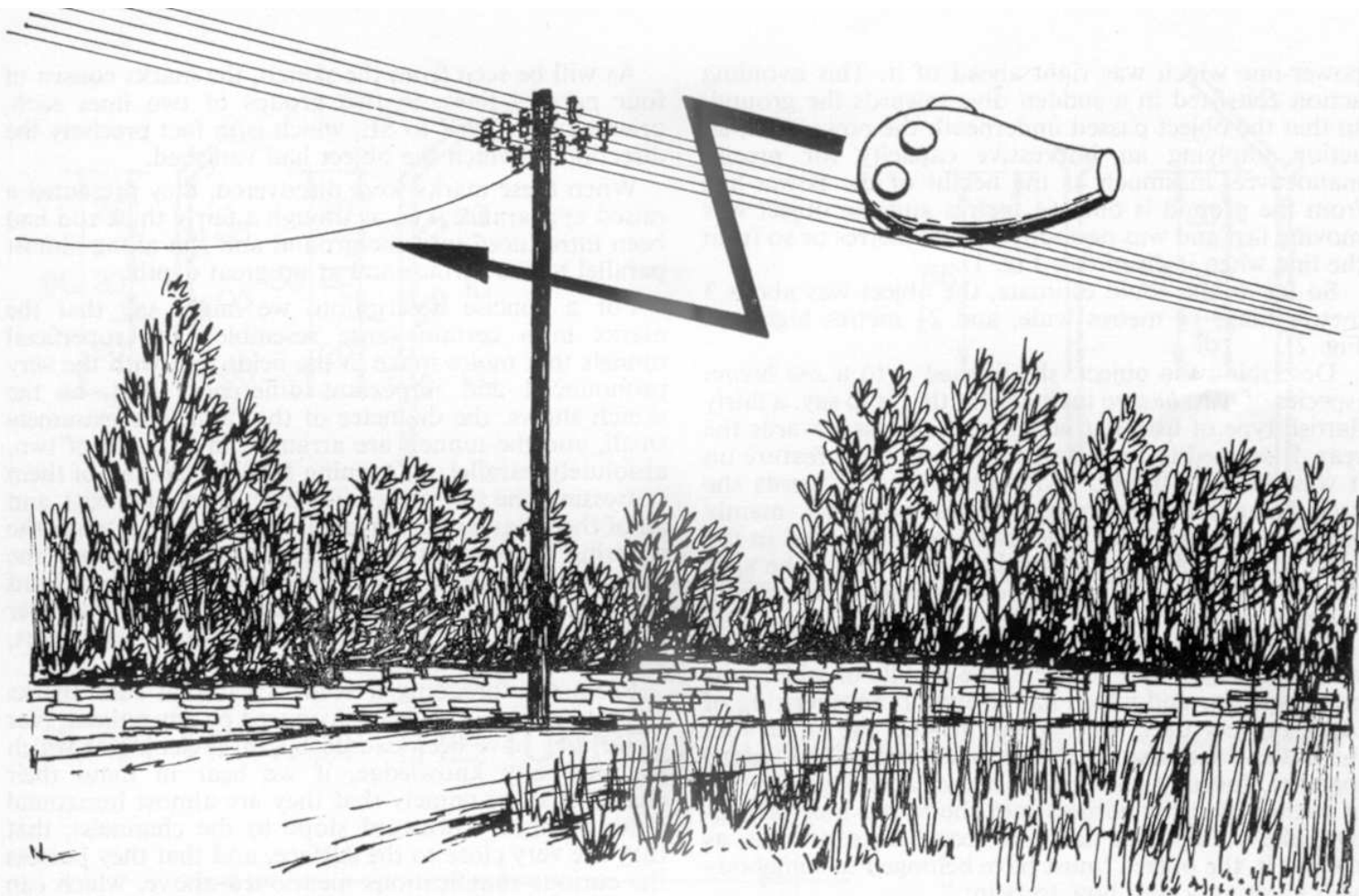

A possible landing at Matadepera

José Maria Casas-Huguet

WE have selected the following case from our files as we think it will be of interest to our readers, notwithstanding the fact that an account of it has already appeared in the Barcelona magazine *Algo*, No. 155 (June 1-15, 1970).

The event occurred in the closing days of January 1969 (perhaps on the 29th) at Matadepera, near Barcelona. The only witness was an old lady of 80, who however is possessed of magnificent and most enviable health and strength, and whose eyesight, although she does wear glasses, can as we have been able to confirm for ourselves, be described as entirely normal. We can likewise affirm that she is sound in all her other senses, and that on the various occasions when we have interviewed her she has displayed a liveliness and a mental agility that are right outside the range of what is usually found in persons of so advanced an age.

This spirited and charming old lady, whose name we are asked not to divulge (we have given her the pseudonym of Doña Antonia Soler Rius in our earlier, brief version of this report in *Stendek*) frequently goes for a stroll on the hillsides in order to get a little exercise, to gather herbs, and to escape from the monotonous and cramped confines of her house. On the day in question, she went out at about 10.00 a.m. and headed, as usual, for the outskirts of the town.

* * * * *

Señor Casas-Huguet is the President of the Spanish investigation group C.E.I. (Centro de Estudios Interplanetarios) established in Barcelona by Antonio Ribera and colleagues, and publishers of the excellent Spanish journal *Stendek*,* now in its third year of existence. The present article, translated by Gordon Creighton, comes from *Stendek* for March 1972 (Year III, No. 8) and appears with the kind permission of their Editor, Señor Josep Serra, and of the Directing Council.—EDITOR.

It was a very fine day, sunny, with a cloudless sky. The eyewitness was standing by the verge of the road, plucking herbs, when she suddenly heard a loud noise which struck her as most strange and unwonted for such a place. She describes the sound as like that made by a car passing close by at high speed. She at once straightened up and looked around to see what was causing the sound and beheld, coming from among the trees to the right of her, and travelling on a slightly ascending oblique trajectory, "a curious flying object."

As she watched, the object changed course extremely quickly and abruptly so as to avoid hitting a 5,000-volt

* *Stendek* address: STENDEKCEI, Apartado 282, Barcelona, Spain.

power-line which was right ahead of it. This avoiding action consisted in a sudden dive towards the ground, so that the object passed underneath the power-line, an action implying an impressive capacity for precise manoeuvre, inasmuch as the height of the power-line from the ground is only $6\frac{1}{2}$ metres and the object was moving fast and was no more than 20 metres or so from the line when it dived (see Fig. 1).

So far as she could estimate, the object was about 3 metres long, $1\frac{1}{2}$ metres wide, and $2\frac{1}{2}$ metres high (see Fig. 2).

Describing the object, she likened it to a *sea bream* (species of fish: *besugo* in Spanish), that is to say, a fairly flattish type of fish that tapers in thickness towards the rear. It seemed to be metallic, and a notable feature on it was the very bright, vivid colouring, the words she used being that the thing "was all coloured, mainly green and yellow," the colours being distributed in the form of spots and leaf-shaped marks. Where the spot was yellow, then the leaf or zone around it was green, and vice versa.

On the belly or under part of the object she could see very distinctly a sort of circle, the middle of which was orange-yellow and which had around it another ring of black or very dark blue. Then, around the latter still, there was a circular area with green and yellow mixed together, forming, as already stated, a very pretty sort of pattern that the witness said she found most attractive, like nothing she had ever seen before, so that, as she put it, the object "must have belonged to somebody who knew very well how to paint."

On the front part of the object there were rounded or spherical protuberances. She saw no portholes or windows or doors. In other words, the surface seemed to her to be smooth and uniform.

Figure 1 shows how, in its manoeuvre to avoid hitting the power-line, the object dropped abruptly and shot through a gap, approximately 6 metres high and 4 metres wide, between the post of the power-line on the one hand and a small pine tree, not very thick and less high than the cable, on the other hand.

Once past the obstacle of the power-line, the object began to rise again gently and rapidly, in the way that an aircraft climbs, and made off at good speed and at no great height, over the low houses and the pine trees, towards Terrassa, a town some 6 km. from Matadepera.

But that is not the end of the affair, and what follows may be of great significance.

The first report of this case came to us from Señor Joan Fonolleda Prat, our representative at Sabadell. Sr. Fonolleda asked the old lady to accompany him to the place so that he could make an inspection and look for possible marks or other evidence of a landing. The result was that, close to where the old lady had stood when she had the sighting (the actual distance was 30-40 metres), he found some curious marks on the ground.

As soon as the report about these marks reached us at C.E.I. a group of our members set off to examine the spot.

Figure 3 shows the nature of the marks.² Since it has been quite impossible to find any conventional explanation for such marks, they constitute the only piece of evidence we have that a UFO had [possibly] landed at that place.

As will be seen from the sketch, the marks consist of four parallel lines, in two groups of two lines each, oriented from NW to SE, which is in fact precisely the direction in which the object had vanished.

When these marks were discovered, they presented a raised appearance, i.e., as though a fairly thick rod had been introduced into the ground and run along almost parallel to the surface and at no great depth.

For a concise description, we might say that the marks in a certain sense resembled the superficial tunnels that moles make in the fields, but with the very pronounced and important differences that, as the sketch shows, the diameter of the tunnels is extremely small, and the tunnels are arranged in two sets of two, absolutely parallel, all running NW-SE, and all of them possessing one sole orifice (for both entry and exit), and all of them having this distinctive feature that, when the covering layer of earth was removed from above the little channels, caused by the introduction of some hard body into the ground, there became apparent a number of curious equidistant lateral ramifications, very short, and of very small diameter.

From the foregoing it seems clear that such marks cannot possibly have been produced by any animal. Nor could they have been caused by any machine of which we have any knowledge, if we bear in mind their characteristics: namely that they are almost horizontal (with a slight downward slope to the channels), that they are very close to the surface, and that they possess the curious ramifications mentioned above, which can be seen clearly from Fig. 3.

It is also worth mentioning that inside these small channels, in the soil, it could be seen quite clearly that the earth had been compressed against their walls. This adds plausibility to the thesis that some hard, rectilinear, narrow object had been introduced into the ground under great pressure.

Of the two sets of marks that were found, the left-hand pair were a lot more pronounced than the other pair. (There were also four more marks, at a distance of some nine to ten metres, but as these were very indistinct and ill-defined, we prefer not to make any statement about them.)

When we had removed the surface soil covering the two pairs of more clearly defined marks, in order to examine the interior of the small channels—which seemed not to contain anything—we made a plaster cast of one of the marks, although, as was only to be expected, it did not turn out perfect and was considerably bigger than the original. We also made a model, in special soft clay, of the object seen by the eyewitness and as described by her to us.

Finally we might add that the lady experienced no shock of any kind, nor any other type of negative after-effects from her experience. On the contrary indeed. She was extremely pleased and satisfied at having seen "something so pretty." She had never previously heard anybody speak of UFOs. On the other hand, as she assured us, she knows very well indeed what an aeroplane and a helicopter look like, and she can distinguish between them. She had some difficulty in pronouncing the word helicopter, which is a new term to her and remote from her mentality and her degree of education,

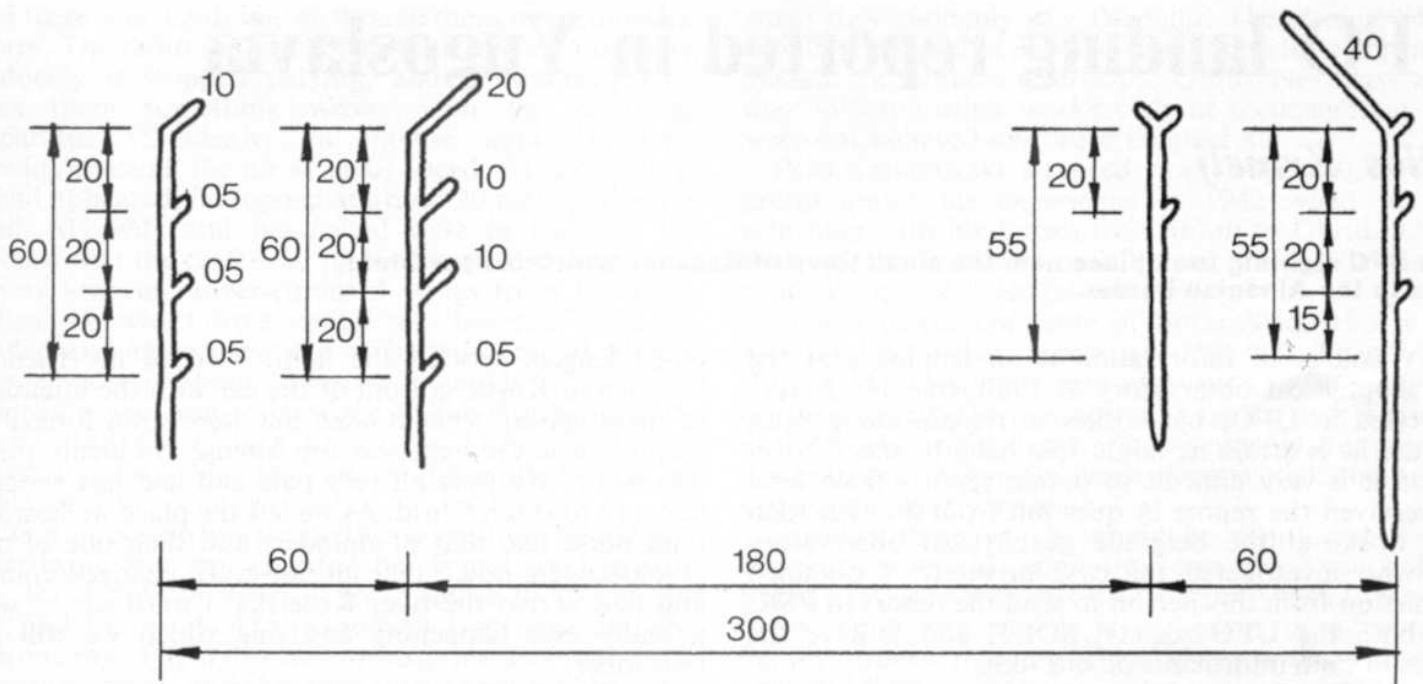

PLAN VIEW OF THE TUNNELS (ALL DIMENSIONS GIVEN IN CENTIMETRES).

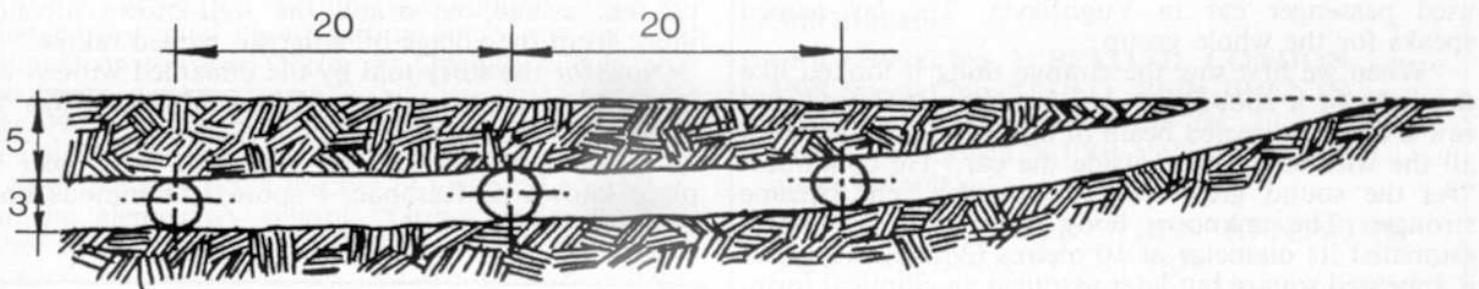

SECTIONAL VIEW OF THE TUNNELS

but she says she has seen helicopters a few times on her TV set.

She assures us that what she saw was something totally and absolutely unknown to her, and she is unable to say what it could have been, which is easy to understand since, in similar circumstances, we would find ourselves in the same position. One curious point is that she insisted that what she had seen must have been something "from abroad", hoping thereby to indicate no doubt the degree of strangeness and surprise that the episode held for her. And as we know well, in past times, and indeed even today still, there are folk for whom the word "foreign" is a synonym for the

remote, the strange, and the surprising . . . something out of the way and rare.

Notes by Gordon Creighton

- 1 Readers are reminded that Barcelona lies in Cataluña and that the mother-tongue of the members of C.E.I. is not Castillian Spanish, but *Catalan*, a proud, separate, and ancient member of the Latin family of languages. *Joan* in Catalan is the equivalent of the Castillian *Juan*, and refers therefore to a man and not to a woman as English-speaking readers might have thought.
- 2 While it is not suggested that the markings are identical, it might be well to study them in conjunction with the equally mysterious markings found at Marliens in France (see FSR for September/October 1967).

We rely on our readers' recommendations, so . . .
TELL YOUR FRIENDS ABOUT *FLYING SAUCER*
REVIEW* and *FSR CASE HISTORIES

UFO landing reported in Yugoslavia

Milos Krmelj

This UFO sighting took place near the small town of Rasanac which is near Ohrid, close to the Albanian border.

MY source of information is an employee at the geophysical observatory at Ljubljana. He is very interested in UFOs but wishes to remain anonymous because he is afraid he might lose his job, and for this reason it is very difficult to obtain reports from him. He received the report in question from another man who works at the Belgrade geophysical observatory and who investigated the case privately. I obtained permission from this person to send the report to FSR, and both the UFO society, SOLT, and I, have the names of both informants on our files.

The occurrence took place at 1.00 a.m. on August 2, 1971. The principal witness wishes to be unnamed, but we have his name on file. Other witnesses are members of the beat band "Dubrovacki Trubaduri," namely Kosta Verus, Stojan Klatovski and Milorad Dusanovic. They had been travelling in a Fiat 750, the most widely used passenger car in Yugoslavia. The last-named speaks for the whole group:

"When we first saw the strange thing it looked like the light of a spot-light; we also heard a sound and saw a strong, directed beam of light." (At this moment all the witnesses were outside the car.) He continues: "As the sound grew stronger, so the light became stronger. The unknown body hovered in the air. I estimated its diameter at 10 metres (33 feet). At first it appeared square but later assumed an elliptical form. The light grew even stronger. It was stronger on the edge than in the middle. Because of the configuration of the terrain we were unable to see whether the object actually landed or not, but we clearly saw rays coming through the forest trees. We were certain the object was either in or behind the forest which is near the Ohrid-Bitolj road, lying no more than 40 metres (125 feet) back from the road-side.

"It was really interesting to watch that unusual object. First we saw it as a square, and it gradually reshaped to become an elliptical body. It then projected a very strong beam of light. Even I was determined to go to the place where the strange thing hovered or landed, hoping to see what it was, but I was unable to do so owing to the intensity of the light. I had not believed my friend who told me that only the day before he had met with an unusual object at that very spot.

"Just before we encountered the strange light, when we had reached the small town of Rasanac, I had seen a small green frog jump from somewhere onto the steering wheel. Only a moment later, someone shouted to me to take care as a scorpion had appeared on the door. When I was a child I was afraid of that small creature because it is very poisonous. At that moment I stopped the car and it was then that one of the

co-passengers spotted the light. Two of my friends, Stojan and Kosta, got out of the car with the intention of investigating what it was, but were soon forced to stop because the light was too intense. Suddenly there was panic. We were all very pale and had just enough strength to reach Ohrid. As we left the place we heard a loud noise like that of thunder, and then one of my co-passengers noted that an 'air-craft' changed course and flew across the river Koselska. I must say, it was a really rare happening and one which we will all remember."

Golubinka, wife of Milorad Dusanovic, said: "I have no words to describe how Milorad looked that night when he arrived home. He simply was unable to say anything. He was so pale that I was very worried. To pull himself together, he took a bath, even though it was very late (2.00 a.m.); in the morning, as soon as he was awake, he drank the well-known alcoholic liquor from the village of Volgosti, named rakija."

Now for the story told by the unnamed witness who is an administrator of the Ohrid Museum. We will call him after his initials, Mr. N.C.

"It was about 1.00 a.m. when we came near the place known as Rasanac. I spotted a luminous body,

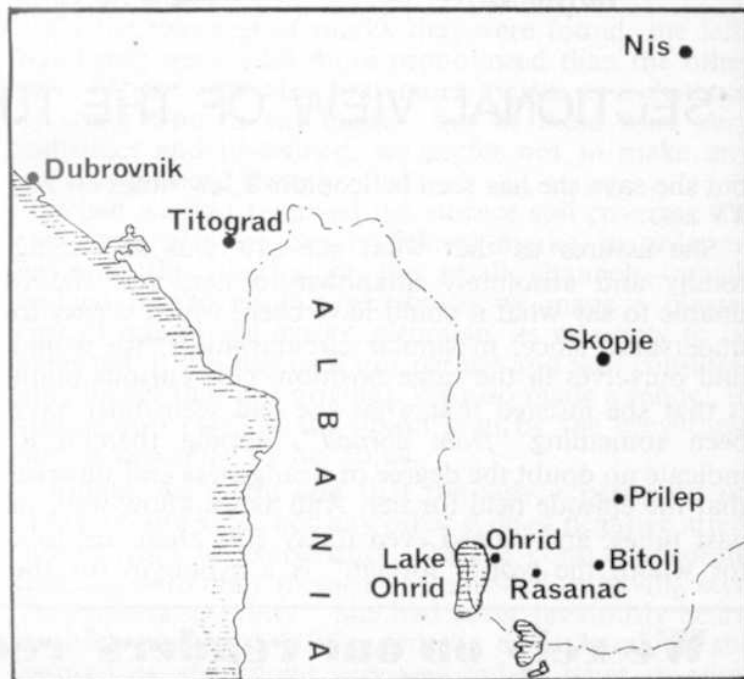

Southern Yugoslavia, showing the location of Ohrid (formerly Ochrida) and district. The lake is surrounded by mountain peaks ranging from 4,500 to more than 7,300 feet

and there was 'lightning' as though there was a thunderstorm. The radio until now had been playing normally. Suddenly it stopped playing, and I wondered why. Was there something wrong with the electronic apparatus? Suddenly, an intense light appeared, moving through the air at great speed. As suddenly as it had appeared, it stopped at about 20 metres over the land. My wife and her friend were in the car. We noticed that the craft was 10-15 metres across and that it was lowering silver-coloured wings from its edges. When the wings were completely lowered, it gently landed and again drew the wings back into the body. The wings were about 10 metres in length. As the thing stopped it was seen to be like a ball in shape, perfectly round, and silver-green in colour. Then suddenly it began to glow. The landing on the earth was at an angle of 90°.

"Out of curiosity I wanted to get out of the car and investigate. But my wife and her friend tried to stop me. But I did not listen to their advice to stay in the car, and I got out. At the moment I got outside I felt a strong ray of light directed towards me. For a moment I was shocked and became unconscious. The light acted hypnotically and I was unable to stay on my feet. My wife and her friend pushed me into the car. When I had recovered I left the place and went on towards Ohrid. About 10 metres further on I stopped again at a parking place near Porenta bridge. Then I saw in my mirror that the light was coming closer, so I changed my mind about getting out of the car and continued on towards Ohrid. At Openica village, the radio began working again."

Mr. N.C. related how next morning he went back to the place with some of his friends and was joined by Mr. Sotir Stefanovski, a teacher of technical education from the elementary school "Grigor Prlicev". The teacher said later that in 1953 the same thing had happened to a group of workers from Pesani village when they were returning home late at 11.00 p.m. from Ohrid. It happened over the hydrometeorological institute. The group of workers were walking along

when they suddenly saw the light. The strange object extended wings and suddenly an intense light appeared. Scared, the workers returned to Ohrid. Next day, when they told the other workers about their sighting they were not believed and were laughed at.

Pero Krstanovski, a retired worker aged 60, told the group about his experience in 1942 when he was returning with his horses from Bitolj to Ohrid. At the same place, Rasanac, and Prents bridge, the horses suddenly stopped. He related thus:

"I was in the company of Boris Alac, who is still alive. I know that horses are very touchy animals. Boris said to me that there must be a reason why the horses stopped. Then we noticed near the river Koselska an intensely bright flame which suddenly disappeared downstream. When the flame disappeared, the horses started on their way again."

Another thing which should be mentioned is that there is a story that some time ago, Dr. Vasil Lahtov found a grave near Prents Bridge dating back to Roman times. Some say that it is the grave of a princess. People believe that the grave glows with an orange-coloured light.

All the witnesses to the above sighting swear on their lives that what they state they saw is the whole truth and nothing but the truth.

Still available

FSR Special No. 2: **BEYOND CONDON . . .**
 FSR Special No. 3: **UFO PERCIPIENTS**
 featuring *The Strange Case of 'Dr. X'* by Aimé Michel (continued in FSR Vol. 17, No. 6—also available).

WHY NOT ORDER WHEN RENEWING YOUR SUBSCRIPTION from

**FSR Specials, 21 Cecil Court
 Charing Cross Road, London WC2N 4HB, England**

DID YOU KNOW THAT . . .

The highlight of the remarkable Papuan (New Guinea) 'wave' of 1958-59 was the observation, by Father William Gill, and his congregation, of a

UFO WITH HUMANOID OCCUPANTS 'ABOARD'?

Read the Rev'd Norman Cruttwell's classic account of these events in FSR Special Issue No. 4,

UFOs IN TWO WORLDS

Other contributions by

V-J. Ballester Olmos, Jacques Vallée and Gordon Creighton.

Fully illustrated, 64 pages, price 60 pence (£0.60), overseas 65 pence (£0.65) or \$1.60 (adjusted due to new rate of exchange).

FSR (Special 4), 21 Cecil Court, Charing Cross Road, London WC2N 4HB, England.

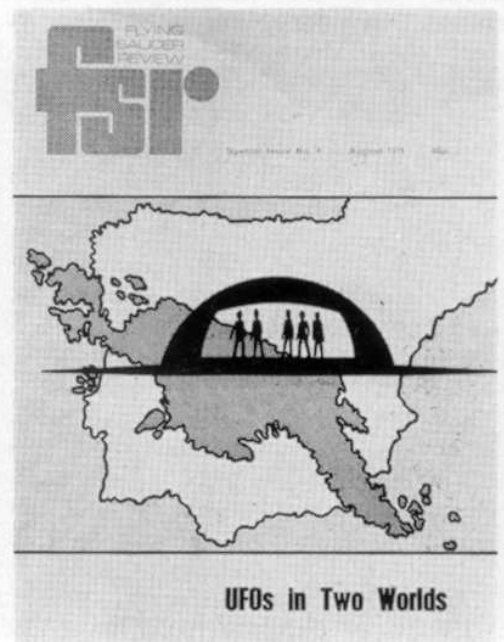

UFO Photographed over Okinawa

Jun-Ichi Takanashi

Our contributor is Chairman of Modern Space Flight Association* and the following report is taken from this Japanese group's *UFO Newsletter* of September 27, October 5 and October 11, 1972.

AROUND the time that a TWA pilot and two crew members sighted a UFO over the Western Pacific off Okinawa at approximately 8.00 p.m. Japanese Time (11.00 a.m. G.M.T.) on September 22, 1972, two photographs were allegedly taken by a senior high school student in Okinawa. This was reported by two of Japan's five leading newspapers, the *Yomiuri Shinbun* and the *Mainichi Shinbun* on September 27, 1972.

The student who took the photographs is Mr. Masahiro Asanuma (aged 21), 4th Grade Correspondence Course student of Oruku Prefecture Senior High School, and who lives at 91-2, Yorimiya, Naha City, Okinawa. They were taken when he was attending the Summer School Camp of the Correspondence Course held at the Young People's Field Centre at Uji, Nago City, in the central part of Okinawa Island, together with forty schoolmates and their teacher, Mr. Yoshio Takaesu†, who also witnessed the object.

At about 8.30 p.m., according to the *Mainichi*, a bright object, brighter than the moon, moved from west to east in the north-western sky. The object made its appearance in the night sky at about 50° altitude in the form of a yellowish-white belt of light. At the time, the witnesses were admiring the full moon, as it was the Day of the Harvest Moon (the Japanese enjoy the full moon once a year on this day—one of the outstanding events in the life of the Japanese people in general). The object flew slowly from the western coast of Heneji to the east in the direction of Kunigami.

Although the moonlight was very bright and the sky was rather light, the object was "fluorescent-coloured, like the moonlight," according to Mr. Asanuma. "An aeroplane is burning! No, it's a flying saucer!" the students cried. Having heard such cries, he aimed his camera (a Cannon 35 mm. QL, with 50 mm. lens, iris 1.9, using Fuji film, monocro SS) and released the shutter four times. He took the first two photographs of the object with flash, but they were failures. Then he set the shutter at B, and took the next two photographs with the iris open and pressed the shutter for about 5-6 seconds each. These two were the photographs which caused the sensation. The object finally disappeared into the cloud about two minutes later.

There are scores of other witnesses of the same, or a similar object, at about the same time in various parts of Okinawa, such as Daitojima, Koza City, Kunigami-Mura, Ogimimura and Naha City, etc. But as to whether this was the same object which was observed by the pilot and crew members of the TWA flight (and also of the KLM flight) we cannot give you a definite answer because the speed was reported as being different. Furthermore, we have already received one newspaper clipping from a member in Okinawa (from the *Okinawa Times*) which reported other sight-

ings of the same object on the same night by some other residents in various parts of Okinawa. However, these reports show that the object flew approximately from north to south, leaving a wide trail, and not from west to east as described by Mr. Asanuma. What does this mean? Was there a misunderstanding of the direction on the part of the student?

* * * * *

There was another photograph taken during the early morning of the next day, September 23, in Osaka City. This was reported in the *Nippon Keizai Shinbun* of September 28 as follows: "On September 27, when the UFO photographed over Okinawa became a topic



Masahiro Asanuma's first photograph



Asanuma's second photograph: eyewitnesses described the object's swift direction changes, but there also appears to be a degree of hand-shake

in the street, a photographer living in Osaka visited us and submitted a photo saying that a strange object had showed up on his photo too . . ." He is Tatsuro Okazaki (aged 41), who lives in Takeyama Building, Tsurigane-cho, Hijashi-ku, Osaka, where he has a small camera shop. I visited him on September 29 and heard how it was taken.

He wanted to take a photograph showing the successive positions of the moon in the sky during the whole night for the enlightenment of his 9-year-old son, Shin-ichi, but in order to do so, it was necessary to take four frames. He fixed his camera, a Fujica 701 with 28 mm. wide-angle lens, on top of his building, and made successive exposures from about 10.00 p.m. to 5.00 a.m. He selected the night of the Harvest Moon. Exposures were made by opening the cap in front of the lens by hand, approximately once every 30 minutes, for 1-3 seconds each, depending on the brightness of the moon at the time, with iris 5.6 and shutter left open. Sometimes he made 2-3 successive exposures at a time, so that 2 or 3 images of the moon were caught closely positioned with each other. In the photograph in question, six images of the moon are shown diagonally in the left-hand corner of the picture (two exposures at the first time, one exposure at the second time, and three exposures at the third time), about 30 minutes apart from each other. When the four photographs were pasted up together in a fan arrangement, this resulted in one big frame showing the movement of the moon that night.

In the top right corner of the resulting large frame, an enigmatic trail of something is caught by the lens. It is described in the newspaper as a "tail of light just drawn by a fine brush, with a starry point". In fact, there is also discernible a second, faint knot in the lower tail and a faint side arm to the right.

As to the nature of this strange image, the newspaper comments: "At first it was hinted that it was the planet Venus, but as the planet Venus could not be in the western sky in the morning, this speculation was cast away at once. Mr. Fumio Toda of the Astronomy Department of Osaka Municipal Electrical Science Museum denies the possibility of its being a star, saying 'It is too low to be Capera (0.1 magnitude).' As it was just after the sighting of a strange flying object in Okinawa, people said that it too may have been a flying saucer, but all the specialists were against that idea. Professor Shigeji Fujinami of Kyoto College of Arts and Textiles, who is an expert on astronomical photography, says: 'It may have been a trail of a meteor, or the phenomenon of aerial electric discharge. But if it was not, then it may have been a mischief of the camera.'"

I do not think it was a "mischief" of the lens, and prefer the former hypothesis, i.e. that of "trail of a meteor" but can a meteor progress in such a complicated way? Could the wind disfigure the trail? . . . That is a point to check.

* Address: G.P.O. Box No. 910, Osaka, Japan.

† This pronunciation may be wrong. Although we use the same Chinese characters here in Japan proper and in Okinawa, the pronunciations in Okinawa are rather strange and we cannot know them without checking them directly.



Tatsuro Okazaki's composite photograph



Enlarged detail from Okazaki's photograph

A French landing in 1944

F. Lagarde

This article has been prepared from a translation, by Gordon Creighton, of a report, with commentary, that was published in *Lumières dans la Nuit* No. 118 (June 1972).*

THE statement of the eyewitness, Madame Madeleine Arnoux, is as follows:

"These happenings date back to the summer of 1944. I was 13 years old then, and I used to go on my bicycle every week to a farm several kilometres from my home in order to get some provisions. Leaving Toulon-sur-Arroux (71) (Michelin map No. 69, sheet No. 17) I was riding along the pleasant road RD 42, which is lined with woods, towards the village known as Le Verger.

"Shortly before arriving at the village, I dismounted to pick some wild berries that I knew I would find there. At that point there is a dirt-road that forks off from the highway and runs away to the right through the woods. It was along this dirt-track that I was walking, slowly, looking for berries as I went. Quite mechanically, I looked up . . .

"A few hundred metres further on, the road climbs a bit and takes a pronounced curve to the right and disappears in the woodland. And it was precisely at that spot that the *thing* was standing, stationary. I recall that it was a very warm day, thundery, and that the sky was pretty overcast.

"Well, then, up there ahead, something was standing beside the trees, and there were some beings quite near it. Looking back on it now, I think the machine must have been of about the size of one of our small cars today (Volkswagen class), and it was of a dull metallic grey colour. I don't remember whether I noticed any openings in it. The beings that were beside it must have been less than 1 metre in height, and were dressed in a sort of brown-coloured overalls. They made no motion or gesture in my direction, and I, for my part, was rooted to the spot.

"How long did this mutual observation of each other last? I can't say, but I remember the oppressive atmosphere and the thundery state of the weather, and I remember how I had the feeling that I was unable to move . . . Then suddenly I was able to do so. I wanted to get my bike, which was lying a few metres from me. It took just the time needed for me to bend down as I got it, and then, when I looked up again towards the strange apparition, there was nothing there . . . All there was to be seen, at the spot where it had been, was a violent wind blowing the trees about. I didn't think of looking up in the air, where, if I had done, I should no doubt have still been able to see the machine as it was flying away.

"I was terrified and made off at full speed to the farm, where, needless to say, I didn't say a word about it! And nor did I talk about it when I had got back home either, for I felt sure I would be called a liar and a hoaxer. For a long, long time I thought about the weird encounter, and then I forgot about it . . . And it was only when people began to talk about "flying

saucers" that I put two and two together and began to think that without doubt what I had seen was one of these mysterious UFOs.

"After all these years, the picture is still very clear in my memory and I know perfectly well that I wasn't dreaming and that what I saw that day in the woods wasn't anything that is "known". It couldn't have been any vehicle existing at that time—and they were pretty rare on the roads anyway—for I would certainly have identified it as such.

"The scene of the encounter was a lonely place, the road leads into the woods, and the nearest farms are a kilometre or so distant. It was 1944, and the Maquis people of the Resistance were quite plentiful in the area, but it couldn't have been any of them. Nor could it have been German soldiers, and had it been either Maquis or Germans, unquestionably they would have challenged me. So one can only think that I must have been a witness of one of the earliest UFO visits.

"I attach two rough sketches of the place, but in order to be more precise I should have to go back there again."

* * * * *

We are grateful to Mme. Arnoux for her report. The important facts remain, even if the sketches are made from somewhat imprecise memories. How many of these important events there are that are still unknown to us! And no doubt the responsibility is ours, because *Lumières dans la Nuit* does not circulate widely enough.

Incidentally—although of course Mme. Arnoux does not know this—the delightful Highway D 42 runs right across a *geological fault*, 110 km. long, which is to the west of Toulon-sur-Arroux and consequently quite near to the landing site.

She is no doubt equally unaware of some other very interesting cases from the same area. For example, the sighting over the wood at Chazey, 14 km. to the south of the site of her observation, where the engine of a car cut out and the lights failed (Aimé Michel: *A Propos des Soucoupes Volantes*, p. 214). Then there was the other incident at Montceau-les-Mines (Aimé Michel, *ibidem*, p. 213), 20 km. to the East from her sighting point, where it was the motor of a powered bicycle that cut out. Finally there was the case at Ciry-le-Noble (Aimé Michel, *ibidem*, p. 213), 18 km. to the South East, where the eyewitness was blinded by a saucer. And many other cases there are too that we have published, cases which show that the region in question is one much frequented by UFOs, which fact, together with that of the geological fault there, does much to lend additional credibility to this present report from a solitary and unsupported eyewitness.

* Address: "Les Pins", 43-Le Chambon-sur-Lignon, France.

Preliminary Catalogue of Type 1 cases in Argentina

Prof. Oscar A. Uriondo

THE documentary material in this Preliminary Catalogue has been arranged according to the four classic subdivisions of Type 1. But for reasons of systematization various sub-classifications have been made in each of Dr. Jacques Vallée's basic groups.

In this connection we feel that we should explain moreover that the initial figure given for each case refers to the serial order of the event within the class to which it belongs. On the other hand the figure in parentheses denotes the chronological position of the case within the total context of all the classes. This last-named arrangement is the one followed by Dr. Oscar A. Galíndez in Table V of his complementary work, to the terms of which we also refer in connection with the specification of methodology and the criteria of selectivity used for the present compilation.

The place-name given in brackets is the name of the Province.

SUB-CLASS A-1: Visibly abnormal body or phenomenon situated on the ground

1. (2). 1950, March; Las Catalinas farm (near Bahía Blanca, Prov. of Buenos Aires). 20.25 hrs.

Six people (including the owner of the farm, Señor Juan Girotti and his wife) observed the landing of a luminous object, shaped like a half-moon, which remained on the ground for 20 minutes.

Vogt, C: *El Misterio de los Platos Voladores*, Buenos Aires, 1956, p.77.

2. (7). 1957, January 18; Campo Quijano (Salta). Morning. A flying body of metallic appearance and of oval shape, vividly reflecting the rays of the sun, descended slowly on to one of the slopes of the peak known as El Cerro Negro. Numerous people observed the phenomenon (some with binoculars) over a period of seven hours, until it became obscured by clouds.

Riitti, A. C. and Vogt, C: *El Enigma de los Platos Voladores*, Buenos Aires, 1959.

3. (14). 1959, April 17: Dawney (La Pampa).

Workers at the La Carlota farm stated emphatically that an aeroplane of a strange shape had landed in the vicinity, but that it had immediately taken off again and moved away at high speed.

La Razón, Buenos Aires, April 26, 1959.

4. (15). 1959, May 20; Tres Lomas (La Pampa). 17.30 hrs. Two hunters observed a landed disc-shaped object. It appeared to be a machine of aluminium or silvery metal. It was 2.50 metres high and had a cupola 1 metre in diameter. The grass at the landing-site was left flattened.

La Razón, Buenos Aires, May 24, 1959.

5. (18). 1962, January 9; Cuesta del Totoral (Catamarca) 03.00 hrs.

Sr. José A. Filipín and Sr. J. Navarro, returning in a truck to Catamarca, perceived, just as they reached the crest of the Cuesta del Totoral, two powerful lights which were in the sky and were following the truck at almost identical speed. Surprised, they halted, but the lights at once vanished. The phenomenon recurred however at Amadores and this

Professor Uriondo is a member of Dr. Oscar A. Galíndez's* Argentinian UFO Study Group (Círculo Argentino de Investigaciones Ufológicas) the Headquarters of which is in Córdoba.

Professor Uriondo, a Professor of Geography, is a graduate of the Instituto Nacional Superior del Profesorado, and at present holds the post of Director of the Library of the Bank of the Province of Buenos Aires. He studied Librarianship at the University of the Museo Social Argentino, and Natural Sciences (Geology) at the University of Buenos Aires.

He belongs to various scientific and cultural societies of Argentina, including the Society for Geographical Studies, the Argentine Astronomical Association, and the Pedro D. Murillo Institute of Historical Studies. He is the author of numerous publications, including a Geographical Bibliography relating to Argentina, and five books on the UFO phenomenon, published between 1967 and 1972—EDITOR.

time the eyewitnesses were able to perceive a strange cupola-shaped device, similar to the upper half of a bus, which was standing on the slope of the mountain, at a distance of some 100 metres from the road. Beside the UFO there was a second and similar object. Both moved away in a zig-zag fashion and finally vanished behind a small hill. Subsequently, the members of a police commission sent there from Catamarca observed a luminous object which touched down gently on the high point known as Loma Brava.

La Nación, Buenos Aires, January 1, 1962; Review 2001, Buenos Aires, No. 17, December 17, 1969, p.28.

6. (19). 1962, January 22-25; Villa Dique Los Molinos (Córdoba) 21.00—24.00 hrs.

A "squadron" of 15 UFOs, flying above the vicinity of the Dyke, were seen by many local inhabitants. Some of the objects landed on the banks of the lake, while others even moved around on the surface of the water, at no more than 200 metres distance from the eye-witnesses. The diameters of the objects varied between 5 and 10 metres.

Córdoba, Córdoba, January 29, 1962; *Manual de Informaciones*, vol. 4, fol. 2/3, 1962, p.22, published by the Information Service of the Argentine Army).

7. (20). 1962, May 9; National Highway 35, near Bahía (Buenos Aires). 03.30.

José Carlos García, an employee of the Naval Base at Puerto Belgrano, was out on a hunting expedition with several friends. Before they had gone far they saw a glow which they took to be due to the lights of some nearby town; but it proved to be a luminous object, resembling the glow of mercury gas, which rose into the air and emitted two other similar objects. One of them flew along the road above the eyewitnesses' jeep; the other two objects rose vertically into the sky and disappeared. For eight minutes the hunters pursued the third UFO, until it increased speed and disappeared also.

* Our congratulations to Oscar Galíndez on the securing of his Doctorate.

Siete Dias Ilustrados, Buenos Aires, August 8, 1967.

8. (21). 1962, May 12; National Highway 35, Kilometre 72 (Buenos Aires). 04.10 hrs.

Travelling from Bahía Blanca towards Jacinto Aráuz, three truckmen, Valentino Tomassini, Gauro Tomassini, and Humberto Zenobi, observed, in a field, at a distance of some 40 metres from the wire fence, a light resembling a lantern, which kept brightening and dying down alternatively. As they slowed down their truck they saw a row of lights (from 20 to 30) come on, and they had the impression that they were looking at a brightly illuminated railway passenger coach. When they had reached a point 70 metres from the object, it rose up and crossed the road at a height of four metres; its lights went out, and from the lower part of it came a reddish flame and at the same time it made a soft humming noise. The UFO then divided into two parts, which flew off in different directions. At the landing site the grass was burnt over an area 60 metres in diameter, and there were damp leaden-coloured patches which, when analyzed subsequently at the Southern National University, turned out to consist of calcium carbonate and potassium carbonate.

La Nación, Buenos Aires, May 24, 1962;

Los Principios, Córdoba, May 25, 1962; Review 2001, Buenos Aires, No. 5, December 6, 1968, p.20.

9. (23). 1962, May 13; La Araña, 40 km. west of Santa Rosa (La Pampa) 04.00 hrs.

People attending a meeting saw a powerful light which was on the ground to begin with and then rose and moved away accompanied by various luminous objects of similar shape. They seemed to rotate as they flew along.

La Prensa, Buenos Aires, May 16, 1962.

10. (25) 1962, May 13; near Oncativo (Córdoba). 04.00 hrs. Two ladies, driving from Rosario, saw a long object flying at moderate altitude and irradiating a powerful luminosity of many colours. A few moments later the surroundings seemed to be covered with fog and they saw, through the trees, and standing on the ground, a sort of "little house" with green, red and yellow lights set in an arrow-shaped arrangement.

La Razón, Buenos Aires, May 15, 1962.

11. (27). May 1962. Jujuy. 04.00 hrs.

Four people whose car had run out of petrol were waiting during a rainstorm when a bright light—which they at first thought was from another car—approached them. It was a luminous object flying low, and it landed. It was round, with a flashing light. It remained there for about an hour, and then took off at high speed.

Vallée, J: *Passport To Magonia*, U.S. edition, p.271.

12. (33). 1962, August 5; Las Armas-Pirán Highway (Buenos Aires); 01.45 hrs.

The truck driver Pedro Atili was travelling towards Mar del Plata when suddenly his engine stopped for no visible reason. At the same moment he observed an object about 25 metres long standing on the ground, at a distance of 300 metres from him. Then the object took off, emitting a vivid orange light, and vanished at staggering speed.

Gordon Creighton: *Argentina 1962*, in FSR July/August, 1964, Antonio Ribera: *Platillos Volantes En Iberoamérica Y España*, 1968, p.98.

13. (34). 1962, August 12; near Catrilló (La Pampa). Night.

Five truck drivers travelling along National Highway No. 5, from Buenos Aires to Santa Rosa, saw something intensely bright rise from the ground and vanish in the sky at enormous speed.

Antonio Ribera: *op. cit.*, p.99.

14. (36). 1962, September 3; Angaco (San Juan). 22.30 hrs. As Francisco Sosa was riding homewards on his bicycle he saw, at a distance of some 300 metres from the road, an object taking off silently and leaving behind it a bluish luminous trail. At the spot the grass appeared to be burnt over an area 3 metres wide.

La Razón, Buenos Aires, September 4, 1962.

15. (40). 1962, October 10; Mar del Plata (Buenos Aires) 20.00 hrs.

A young man named Enrique Leonardo Bocher was engaged on farm work, using a tractor, in the Peralta Ramos forest, when he saw a great flash of bluish light among the trees. The phenomenon rose higher and moved towards him. He tried to escape, but the engine of his tractor stopped. The bright object passed over him and vanished towards the sea. There were two other witnesses. At the landing site a number of burn marks were found which seemed to have been caused by the UFO.

Antonio Ribera: *op. cit.*, p.102.

16. (41). 1962, beginning of November; Highway between Salta and San Miguel de Tucumán (Salta). Night.

As engineering student José Enrique Torramorell and his cousin Hernán Caverlotti were travelling along by motorcycle, at kilometre 17—after passing the Salta limits—they saw a glowing spherical object pass slowly over them and land on a hill some 500 metres distant. The object was about 20 metres in diameter. The engine of the motorcycle cut out, as did the engines of other vehicles in the vicinity. The two eyewitnesses were paralyzed. Then the object took off vertically, performed a number of movements in the air and landed again and switched off its light. Only then did the young men recover their ability to move. Then a phosphorescent red light came on at the centre of the UFO, while a second and similar light appeared on a neighbouring hillock. Then both lights rose and moved away at high speed. The wiring of the motorcycle was found to be burnt out and the two eyewitnesses had burns on their arms.

La Gaceta, San Miguel de Tucumán, November 9, 1962.

17. (44). 1962, November 26; Road from Abra Grande to Clodomira (Santiago del Estero). 01.00 hrs.

Two haulage men, Francisco Salas and N. Arnardy, were travelling on a tractor drawing a trailer loaded with coal when, shortly after leaving Abra Grande, they saw an object on the railway line which there runs parallel with the road. They thought it was a lighted railway wagon, but on drawing nearer they perceived that it was a sort of gigantic robot emitting phosphorescent flashes. Making no sound it rose up into the air to a height of some 50 metres and then landed again beside the road. Throughout the whole journey this continued to be repeated, in identical fashion. When the first lights of Clodomira came into sight the object broke off the pursuit and, climbing at staggering speed, vanished into the sky.

El Liberal, Santiago del Estero, November 28, 1962.

18. (45). 1962, December 11; near Chumbicha (Catamarca). 02.00 hrs.

Dr. Godofredo Lazcano Colodrero, director of the Sobremonte Museum at Córdoba, was travelling by car from Catamarca to Córdoba, accompanied by his wife, two sons, and a friend. Fifteen minutes after passing Chumbicha they saw seven brilliantly lit spherical objects standing on the slope of a mountain, and at a distance of some 60 metres. The squadron of objects rose straight up into the air and disappeared at great speed leaving behind them trails of intense luminosity.

Córdoba, Córdoba, December 27, 1962; Gordon Creighton, *Argentina 1962*, in FSR July/August 1964; Antonio Ribera, *op. cit.*, p.104; J. Vallée, *op. cit.*, p.289.



Figure 1: Sketch, to illustrate case 19, by Dr. O. A. Galíndez
Key to measurements:
 A : 0.30m
 B : 0.40m
 C : 3.30m
 D : 0.40m
 E : 3.30m

19. (48). 1963, January; Cañada de Alzogaray (Tucumán). Night.

In a field owned by them the brothers Rosauo Antonio, Ricardo, and Víctor Domingo López noticed that, at a spot approximately 2 km. from their house, the grass was burnt over an area in the shape of two rings (each ring 3.30 metres in overall diameter and 0.30 metres in respect of the ring itself (see sketch). On these rings the grass was burnt right down to its roots, to a depth of from 7 cms. to 10 cms. Carbonized residue and a whitish powder were found. It transpired that, some days previously, a neighbour named Juan Gerónimo Perea, overseer of the "El Trébol" property, and his wife and children had seen an extremely luminous oval-shaped object, flying silently, which landed in the field of the López brothers.

La Gaceta, Tucumán, February 5, 1963, and February 2, 1964; Gordon Creighton: *Argentina 1963-64*, in FSR November/December 1965; Oscar A Galíndez: *Les Empreintes Mystérieuses de Cañada de Alzogaray*, in *Phénomènes Spatiaux* No. 21, September 1969, pp.20-22.

20. (49). 1963, March 12; Colonia Yeruá (Entre Ríos). 05.30 hrs.

After a heavy fall of rain Pablo Michalowski and Roberto Jorge Martínez observed and photographed a luminous object which rose out of a forest reserve.

Clarín, Buenos Aires, August 30, 1963; J. Vallée, *op. cit.*, p.291.

21. (54). 1964, February 25; Saladillo (Buenos Aires). Night.

As Juan H. Botta was driving in his car, he observed two highly luminous objects which remained stationary for one hour and then descended, one of them landing in a field near the highway and the other one flying away towards the north.

CODOVNI Bulletin, Buenos Aires, 1964; Gordon Creighton; *Argentina 1963-64 (Part 3)*, in FSR March/April 1966.

22. (57). 1964, May 10; Patquía-La Rioja Highway (La Rioja). 21.30 hrs.

Businessman Máximo Dughetti was driving his van, accompanied by his son and his nephew, when, at a point almost 20 kms. from La Rioja, the engine stopped and the lights went out. From a coppice nearby came a beam of light, bluish white, and dazzlingly powerful. This light then went out, and they were then able to see an object shaped like an inverted dish, 15 metres in diameter and with a

cupola on the upper part. The object was slowly rising into the air and producing a soft hum. It crossed over the road diagonally at a height of no more than 10 metres, and 20 metres from the van, and moved off towards the Sierra de Mogote Colorado range. Then the engine of the van came on again and the lights came on. Next day, in a clearing in the coppice indicated by the witness, the vegetation appeared to have been burnt over a circular area 10 metres in diameter.

El Sureño, Bahía Blanca, July 12, 1965; review 2001, Buenos Aires, No. 18 of January 18, 1970, p.25.

23. (67). 1965, May 24; Paso de las Carretas (Mendoza). 18.40 hrs.

As Darwin Milo Miranda and three others were out hunting, they observed, with binoculars, a large luminous device shaped like an inverted dish land on a hill. On the upper part of the object there was a red light which was constantly changing from one shade of red to another. On landing, the UFO became opaque.

La Tribuna, San Juan, May 26, 1965.

24. (69). 1965, July 19; Villa Rosas (Near Bahía Blanca, Buenos Aires). 1930 hrs.

Various local residents (including a priest, the teacher Señora María Inés F. de Andrés, Señora Goicochea, and Sr. Gómez) saw an intensely bright aerial object discharge another smaller object, which came down and landed in a nearby field. It remained there for five minutes and then took off again and re-entered the larger object.

La Crónica Matutina, Buenos Aires, July 20, 1965; review *Así*, Buenos Aires, July 30, 1965.

25. (70). (1965, July 20; Gobernador Diotti (Santa Fe). 02.00 hrs.

The agricultural worker Gustavo Haiepek witnessed the landing of a small object shaped like a spinning-top and emitting flashes of various coloured lights. The object remained on the ground for four or five minutes, at a spot 500 metres from the home of the witness. Then it rose straight up and vanished towards the south. A police commission established that at the landing-site there were marks on the ground and the pasturage seemed as though petrified.

La Nación, Buenos Aires, July 25, 1965; *La Crónica*, Buenos Aires, July 23, 1965.

26. (73). 1965, August 1; Federal Capital (Buenos Aires). Night.

At the intersection of calle Tandil and calle Laguda in

UFO Occupant at Riachuelo, Chile

This item, which we have had on our files for some considerable time, is taken from *UFO Chile*, issue No. 1, a mimeographed publication which appeared briefly during 1967 and 1968. Translation by Gordon Creighton.

LATE one afternoon towards the end of January 1967, at a place named Riachuelo, near Tres Esteros (Lat. 40°50 S., Long. 73°16 W.) in Chile, an engineer C.F.C.—name not divulged—was out for a stroll in a wood. Suddenly, while sitting on a tree trunk in a clearing, he saw a blinding flash of light, “like a magnesium flare, which left a violet luminosity on the retina.”

Shortly afterwards, as he was about to get up and leave, he observed a very bright light nearby and, on approaching, found to his astonishment a “flying saucer” suspended close to the ground. It was rust-coloured, seemed to be made in one single piece, about 35 metres wide. He observed no openings or windows. It was totally silent, but he felt the sensation of a gentle warmth emanating from it.

Suddenly, as he stood watching, it shot about 1 metre towards the left, and as it did so a sort of projection emerged from it and was withdrawn again shortly after.

A “being” then suddenly appeared below the craft, as though materialising out of thin air. This “being’s” height was about 1 metre 50 cms., and his movements and gestures seemed quite human. He was wearing a one-piece transparent garment, from neck to foot. It was very tight-fitting and showed no folds or creases even when he bent down. He wore no helmet and no shoes. The skin of his face and hands was extremely white, and his hair very long. The jaw was rather prominent, but the nose flattish. The “being” was carrying nothing in his hands, and indeed the arms “seemed glued to the body.” The witness was too terrified to speak or approach, and his body “felt stiff”

as though he were riveted to the spot.

The next development was that suddenly the entity was no longer there, having vanished—presumably into the craft above him, although the witness did not see him go. The craft then began to grow larger and to emit a powerful violet light, which the witness thought was the same as he had seen at the outset when the machine had arrived.

From its original “rusty” colour the machine had now assumed an incandescent red shade, but still emitted no sound or increased heat. Then it rose straight up, very fast, and vanished.

By now the sun was just setting. The witness fled to the nearby house of the friends with whom he was staying, but was afraid to tell anybody of what he had seen. He returned next day to the spot, but could find no marks or traces of any kind upon the ground there.

As a result of the experience, the witness fell ill (unfortunately no details of the illness are given) and it was not until some six weeks later that he wrote a letter to the Santiago newspaper *La Tercera*, which published his story in its issue of February 24, 1967.

* * * * *

Editor's Note

Lumières dans la Nuit (March/April 1968) carried a French translation of the story made from *La Crónica Matutina* of Buenos Aires. The latter paper's account follows what is given above in all respects, except that, instead of saying that the nose was *flattened*, it states that the entity “seemed to lack a nasal appendage.”

TYPE 1 CASES, *Continued from page 11*

Buenos Aires an object, shaped like a spinning-top and of the size of a wheel of a truck, landed on the road. It emitted a bluish light. It then took off again and vanished rapidly. The occurrence was witnessed by two young sisters, Marta Beatriz and Mirta Pionti, who had gone out on an errand.

La Razón, Buenos Aires, September 2, 1965.

27. (79). 1965, September 4; San Justo (Buenos Aires). 01.20 hrs.

José Fernández and his wife were awakened by a strange humming noise which seemed to come from the terraced roof of the house. Going up there, Fernández beheld an oval object, two metres in diameter, taking off vertically into the air. It was emitting a vivid light and was making the humming noise that had woken them. They found at the spot marks and signs of combustion.

La Crónica, Buenos Aires September 4, 1965.

This case also appears in *The Humanoids*, between No. 47 and No. 48 of my *The Humanoids In Latin America*. By an oversight I gave it no number, so it should be treated as

No. 47b., and I made the mistake of thinking that the place was the San Justo near Santa Fe.—G. Creighton.)

28. (84). 1965. Early December. La Invernada (Tucumán). Night.

Returning home in a jeep, the farmer Antonio Lozano saw a very vivid reddish light come down in a field of alfalfa near by. Thinking it must be a trespasser, Lozano shone his own light on it. The reddish light revolved once, moved about 100 metres and then, arriving at the wire-fence, took off and vanished towards the west. On the following day he was able to establish that there was a large curved, forked impression in the alfalfa, which was burnt. There was also a burnt circle 5 metres in diameter at the spot where the luminous object had been seen to come down.

La Gaceta, Tucumán, December 5, 1965.

* * * * *

Cases 29-45, which will complete Sub-class A-1 will be included in Part 2 of this catalogue.

Readers' Reports

Unexpected photographic images

Dear Sir,—I have been prompted to send some photographs for your inspection after re-reading *Flying Saucer Review*, Vol. 17, No. 2, March-April 1971, "New mystery at Warminster."

My photographs (1—6), which are consecutive prints of the whole negative in each case, on ADOX KB 17, taken with a Canon *Demi-Frame* 35 mm. camera with 28 mm. lens. 1 and 2 were taken on the afternoon of Good Friday this year [1972—ED]; 3 and 4 on Easter Sunday at

lunch time; 5 and 6 on the morning of Easter Monday.

The photographs 1 and 4 have similar spots, of darker density than those in the photo taken by Michael Samuels.*

The first photograph was taken in the Imber Firing Range, on one of the public roads to Warminster, but the position from which it was taken should be identifiable from the wrecked tanks seen in the distance. I was driving towards Warminster, looking for places where UFOs are stated to have been sighted, when I

saw the wrecks. I stopped my car (left-hand-drive), wound down the window and took the photo quickly before driving on. I did not see an object, as I hardly looked over the landscape. The sky was overcast.

Photo No. 4 was taken on a quick visit to Stonehenge; the weather was cold and windy, and the sky overcast. I quickly walked round the stones and then took the two photographs, the second (No. 4) at right angles to the first (No. 3). I do not recollect looking into the sky at the time.

On neither occasion did I see the objects, which only came to my attention when I was examining the negatives. In the case of the Stonehenge photographs no one at the site was apparently looking at the sky, or noticed the object.

I do my own developing and printing, and have not retouched the negatives or prints in any way. I enlarged the negatives to the maximum of my enlarger, and made positives of the objects on *Kodak* 35 mm. positive film. From these I made negatives which have been further enlarged into the enclosed prints.

I regret I am unable to comment on the exposure, or the light readings, as I was relying on the coupled meter in the Canon, and didn't notice the aperture, or the speed.

I am sending you these photographs to examine on their own merits on account of the similarity to Mr. Samuel's photograph. Should you consider further tests are warranted I will gladly supply the original negatives, together with any further information you may require.

Yours truly,
A. D. Clapham,
Skidby, Cottingham, Yorkshire.
November 8, 1972.

* There appears to be a spot lower down to the left of the stones in photograph 3 as well. We have asked Mr. Clapham for a loan of the negatives, which we will send to Mr. Percy Hennell for examination and comment.—EDITOR.

The negative strip has been examined by Mr. Hennell, who says that he suspected immediately a non-UFO, or non-"light phenomenon" cause as the spot appeared on three different frames at two different sites. Indeed, if an object in the sky had produced the images on the Stonehenge photographs, it would have been enormous, and the many visitors to the site would have seen it. Mr. Hennell feels sure that in this case the "image" was caused by a loose speck of dust on, probably, the rear element of the lens.

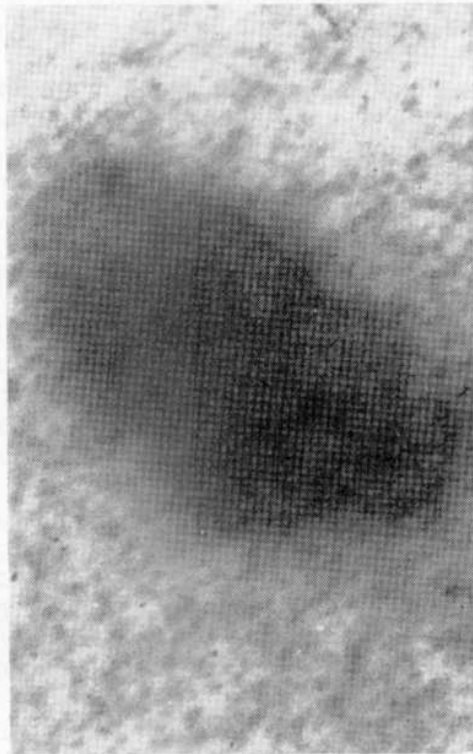
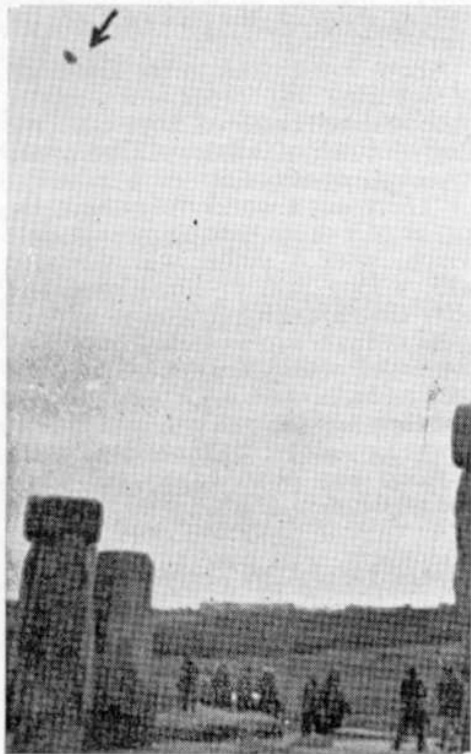

1. The fourth of Mr. Clapham's strip of photographs. A similar spot appeared in different positions on the left of photos 1 and 3 (not reproduced)

2 and 3. Enlarged details from the fourth photograph

New Jersey photograph

Dear Sir,—Dr. Berthold Eric Schwarz, M.D., has asked me to write to you about the enclosed photograph, which was taken in January, 1967, by James Bjornstad, a research consultant at the Christian Research Institute of Wayne, New Jersey, U.S.A.

Mr. Bjornstad stated that he was at the Immaculate Conception Seminary at Mahwah, N.J., when he heard a humming noise, and saw a 30ft. "flying saucer" overhead. He snapped a photograph of the object before it took off into the sky, almost vertically to the right, at a high speed.

"The colour was crazy, a darkish grey . . . you could call it a blackish grey colour," Bjornstad said. "There were no lights, just a slight hum. The photograph was taken at about 1.00 p.m."

The photo was taken in colour, and I made a black and white picture from it. Personally I find no fault with either the story or the photograph, and, most important, I am very impressed by James Bjornstad himself. The Director of the Christian Research Institute, and all others to whom I spoke, have high opinions of him.

Thank you,

August C. Roberts,

P.O. Box 152, Wayne, N.J. 07470, U.S.A.

May 27, 1972.

A shining white "plank"

Dear Sir,—I have come across a UFO sighting made by two people known to me and whom I am sure did not imagine it or make it up. They are Mr. and Mrs. L. H. West, East End Cottage, Barford St. Martin, Near Salisbury, Wiltshire. The date of the

sighting was June 15, 1957, and the couple were travelling from Newbury to Hungerford, Hampshire, on the A4 road. The sun was just setting at the time, and the sky completely clear of cloud. Mr. West has given permission for his account to be printed in *FSR Case Histories* and is as follows:

"After we had travelled a few miles my attention was drawn to a very bright, shining white object quite high in the sky. I stopped my car to observe the object more clearly. Both my wife and I looked up and noticed that the object was absolutely stationary, and that it was exactly oblong in shape. There was no haziness about it; its lines were clear-cut. It was like looking at a plank painted white and standing on end.

"After we had observed the object for about 10 minutes, we noticed that it started to pulsate very much like a star appears to do. Then suddenly it turned flat, into a horizontal position, and raced into the sky. The most amazing thing about the object was that within a few seconds it had disappeared completely. It must have gone at an incredible speed, straight up into the now darkened sky. After we watched the minute spot of light disappear, we started to get back into the car. We then heard an aircraft's engine and I noticed an aircraft which I think must have been investigating the UFO. I wrote to the Air Ministry, but they never replied."

M. G. Flippent,

Stratford Road, Salisbury, Wilts.

The haunted sky

Dear Sir,—The residents of the town

of Hatford, in Berkshire, some eight miles from Oxford, were amazed to hear a "hideous rumbling" in the air, followed by a "strange and fearful peal of thunder" about five o'clock in the afternoon of April 9, 1628. The noises, after a while, then assumed the sound of distant cannon being fired at regular intervals, each report ending in a hissing noise, not unlike the sound of cannon balls flying through the air. Approximately twenty such loud reports were heard.

At Bawlkin Green, a village one and a half miles from Hatford, many people saw an object fall from the sky, during the aerial detonations, and a Mistress Greene, who saw it fall, had it dug out of the ground. From an old copy of *The English Magazine*, the following description of the object is given:

"The form of the stone is three-square, and picked at the end; in colour outwardly blackish, somewhat like iron; crusted over with that blackness about the thickness of a shilling; within, it is soft, mixed with some kind of mineral, shining like small pieces of glass. This stone broke in the fall. The whole piece is, in weight, nineteen pounds and a half, the greater piece which fell off weigheth five pounds, which, with other small pieces put together, make four and twenty pounds and better. It is in the country credibly reported that thunder-stones have been found in other places; but for certainty there was one taken up at Letcombe, and is now in the custody of the sheriff."

About five o'clock in the afternoon of August 4, 1642, a similar phenomenon occurred over the little English town of Alborow. One of the witnesses wrote of it:

"There was a wonderful noise in the air, as of a drum beating most fiercely which, after a while, was seconded with a long peal of small shot, and after that a discharging as it were of great ordnance in a pitched field. This continued with some vicissitudes for the space of one hour and a half, and then making a mighty and violent report altogether; at the ceasing thereof a stone was observed to fall down out of the sky. . . ."

A captain Johnson and a Mr. Thompson, who were superintending the launching of a ship at Woodbridge that day, hearing the aerial cannonade coming from the direction of Alborow, took to their horses and hastened homeward to that town, a dog accompanying them. They were upon a heath between the two towns when the mighty report climaxing the aerial detonations was heard. Thereupon they both saw the stone fall earthward, but lost sight of it



The photograph taken at Mahwah, N.J., by James Bjornstad

as it struck the ground. Their dog "followed it by the scent, as it was hot, and brought them to where it lay, covered over with earth and grass, that the violence of its course had contracted about it." The stone had grazed the heath "some six or seven yards". It was eight inches in length, five inches in breadth, and two inches

in thickness.

Upon proceeding to Alborow they met the greatest part of the town's folk, "who were generally all run out of their houses round about, amazed with this noise of war, and descreying no enemy near; when suddenly there was heard a joyful noise as of music, and sundry instru-

ments in a melodious manner, for a good space together, which ended with a harmonious ringing of bells."

John Philip Bessor,
Butler, Pennsylvania, 16001, U.S.A.
[*Fortean, or meteorological, phenomena, but a very interesting tail-piece to this divertissement*—EDITOR.]

The Investigations of General Uchoa in Brazil — Part 1

Gordon Creighton

ONE of the speakers at the recent Fifth Brazilian Congress on UFOs, held in São Paulo, was General Alfredo Moacyr Uchoa. Before an audience of doctors, professors, engineers, architects, psychiatrists, and experienced investigators of our subject, he described some of the remarkable happenings witnessed by the small and select group of people with whom he works. He is at present stationed in the Federal Capital, Brasilia, where it seems that he holds an official position in the Ministry of the Interior.

During his earlier years, General Uchoa—who has had a distinguished career, and is a graduate of West Point as well as of the Escola Superior de Guerra in his own country—had already encountered a number of situations and phenomena that orthodox science was quite unable to explain. This had caused him to develop an interest in parapsychology and, eventually, in UFOs.

The group of people whom he gathered together in Brasilia to study the reports of UFOs included his son Captain Uchoa, of the Military Police, and a number of individuals of outstanding intellectual and mental calibre.

Their first important case arose when a Rio de Janeiro television team arrived, having learned of certain luminous phenomena said to be occurring on a plantation owned by a man named Wilson da Silva and located near Brasilia. The TV team set out for the property, bent on "filming the saucers." A number of experts in parapsychology were invited to participate, and Captain Uchoa chanced to be charged with the security arrangements.

This case, and a number of others, as described by General Uchoa, have been fully reported in an important series of nine long articles by Eduardo Santa Maria in *O Dia*, the Rio de Janeiro paper, commencing on October 26 of this year, and ending on November 4. I propose to give résumés of these cases in this series of articles.

The TV party spent three days and nights at the plantation but failed to see anything and came away empty-handed. Captain Uchoa had however heard enough from the local residents to be convinced that something of real importance had been going on there,

and on his return to the Capital he told his father about it.

General Uchoa and his own group of investigators accordingly set out for the plantation and, after exhaustive enquiries, came to the same conclusion. In particular, they found that many local people considered the plantation to be *haunted*.

In March 1968 they were ready to start a regular watch at the place, together with Sr. Wilson da Silva. They set up their base-camp near the same 200ft. hill which the Rio de Janeiro television men had selected as their headquarters. They made a detailed study of every inch of the ground, but a long time was to elapse before they got their chance to see any sign of the famous luminous globes of which there had been so much talk. For four months they watched, a shift taking up position every night at 7.00 p.m., and watching until dawn. It was by now the Brazilian winter, and the nights were pretty cold, with the temperature a few degrees below zero.

At last, at 7.00 p.m. on July 22, 1968, Wilson da Silva suddenly exclaimed: "It will be tonight, General! I know it! I will guarantee that the saucers will appear tonight, at 9 o'clock, over the hill, in their usual place!" (It was stated that Sr. Wilson, in fact, always "felt," or "knew," in advance when "they" were coming, but he was never able to explain how or why it was that he knew.)

As 9 o'clock approached, they were all waiting expectantly, with cameras and other instruments at the ready. And, precisely on the dot, at 9.00 p.m., at a distance of some 350 metres from them, right above the hill, there was a tremendous flash, described by them as like a magnesium flash.

Wilson tells them all to link hands. One man at once turns pale and becomes very ill, and Wilson himself receives a tremendous thump on the back (there is nobody behind him) which fells him to the stony ground. As the others help him to his feet he explains that he had felt it internally as a violent mental shock which threw him totally off balance.

Meanwhile the light had now disappeared, only to

Continued on cover iii

The sighting at Ghost Pine Mine

W. K. Allan

Bill Allan tape-recorded his interview with the witness, and the recording forms the basis of the following article. The interview is typical of many which Mr. Allan has made following his regular broadcasts on local radio at Calgary, Alberta, Canada.

THE behaviour of his three dogs aroused Mr. Florian Nottell of Three Hill, Alberta, in the early hours of the morning of June 3, 1972.

Said Mr. Nottell: "All of a sudden they started yapping and raising heck, so I got up and looked out, and all of the countryside outside was lit up. I looked around and saw, further away, about six lights [*supposedly on an object*]; up and down they were going, just like a flare, down low again and then flaring up again. Finally I looked out of the other side of the window and the whole countryside was pretty near like daylight. Then I got kind of scared. And then it started moving around. It came down and went around and over the Texas gate, straight out. Then I jumped on a chair to see how long it would take to go up to the top of the hill (it takes a car about 30 seconds) and by the time I got up on the chair everything had become dark and I could see nothing more."

Allan: "Tell us again how big the lights were."

Nottell: "Well, the lights were at least four times bigger than a car's round. [*We wonder if he means four times the circumference of a car's headlights, rather than four times the circumference of a car?—ASST. EDITOR.*] They went out like a broom [*the rays flared out?*] and there would have been six or eight of them. Now when I went out to the back and looked, there were four lights, one on each corner, one at the top and one at the bottom at road level."

A: "Oh, it was like a great big box."

N: "Yeah, that's what it was. I thought at first it was a cattle liner but it couldn't have been because the lights were too low and too big. A cattle liner hasn't got four lights the same size."

A: "You said you didn't hear a sound at all"

N: "No sound. Just as quiet as could be."

A: "I don't think we have the colour of the light."

N: "Well, it wasn't like a car's lights. I think it was more bluish—fire with blue in it I think. In fact I didn't watch too much about that."

A: "I think you mentioned that when first seen the lights were right over . . ."

N: "You mean it was on top of the tippie."

A: "Of the mine."

N: "Right on top, on a hill. But anyway, I went up the day after to see what was going on and I didn't see any tracks turning around, or anything at all—just car tracks."

A: "Now the circle you mentioned you saw in the grass, is it anywhere in the neighbourhood of the mine?"

N: "That [*circle*] was out between the Morran bridge and Munson ferry, down in one of the valleys. There

are lots of valleys in there. Now if you want to go in and find it again, I couldn't find it."

A: "When did you see the circle in the grass?"

N: "That was the week after."

A: "Did you hear anyone else, such as the ferry operator, make any comment?"

N: "No. Just Miss Clappison down there. She's seen them there."

A: "Yes, she's seen the lights. So has her brother."

N: "I don't know if she saw them that night or not, but she always sees them there."

A: "She watches them."

N: "You could too, maybe, if you watch."

A: "When you went back, were the dogs all calmed down, or were they upset for a while after?"

N: "Soon as I went to bed again, they all went to sleep, but they wouldn't come off the bed to see who was coming. They always jump down and go to the porch, but not that time."

A: "You mentioned, and we should have it on tape, that the distance between the lights on the front and the back were from here to the house across the road. I would say that this is more than 40 feet, isn't it?"

N: "Well, I don't know exactly how long it was but it was plenty long. I think there were four lights on the side, but I couldn't figure out how I could see the lights this way."

A: "Yes, the headlights going sideways."

N: "But there were about six or eight, and there were lights on this side, on that side, all along, it was all lighted up."

A: "Now tell me, when the countryside was lit up, suppose you had some kind of vehicle, and it had eight headlights on it, on every corner at the top and one on every corner at the bottom, could they light up the countryside like this thing did?"

N: "No, no, they couldn't have done that. I could see for a mile and a half over the hill (well, the rise up there). Everything was lit up all around."

A: "There's one point that I think we should clear up. At the beginning when you said the lights went up like a broom, could you explain again how the lights still stayed at the bottom . . ."

N: "Yes, well let's say that it was the headlight of a car. Well, the headlight would be like sharp fire and that stayed stable, but the rays went up and down; they started small and then went up and spread out, and there were four, or six or eight. It was nice to look at, that thing that made the countryside so beautiful."

A: "They were rays. You don't think there is a chance they were flames? Did the rays look sharp?"

N: "Well, they looked like flames."

A: "And they just flared up . . .?"

N: "Up and down."

A: "Like a gas flare, maybe, when the pressure changes?"

N: "Something like that, but it wasn't going up and down fast, just slowly. That's all I could see. And then it started turning round, and when it turned around there were just two, and when they came down the road there were more again. Now how many—I didn't

count them. I didn't have time to count them."

* * * * *

Assistant Editor's note: The witness's obvious confusion about the number of lights which were present serves to lend credence to his truthfulness rather than detract from it. He merely relates what he remembers of his experience without making claim to having noted features he was unsure of having seen, and without presupposing a UFO explanation.

THE INVESTIGATION OF GENERAL UCHOA

Continued from page 15

reappear, this time pink in colour, to the right of the hill, and "about the size of a house." It was giving out tiny spurts of slightly purplish light.

Wilson da Silva begins walking straight towards it, saying that he is going to try for a mental contact. The rest stand watching, tense.

But after advancing only a few steps Wilson, overcome with terror, comes dashing back, shouting: "*Danger! Watch out for your lives! Put a hand to your chest, everybody!*"

All quickly do so. Clearly Wilson is utterly terrified. Such fear could never be simulated. Without stopping, Wilson has continued his flight towards the station-wagon, while everyone clamours for an explanation. Never, so they argue, has there been report before of anything sinister about the UFOs*. Wilson merely goes on shouting that there is *great danger*. The rest however still hold their ground, unbelieving.

Then the light appeared once more, extremely bright, at the same area as before. This time its colour was light blue. Every man watched it intently as it moved to and fro above the hill, the terrain of which had been exhaustively studied by them over the past four months, so that every bush, every twig, is familiar. Around the light they now perceived a zone of dense

"mist" (described by the author of this series of *O Dia* articles as "apparently serving as a protection against radiation," though it is not stated how this was known).

Suddenly the light makes straight for the party, who at last beat a hasty retreat. The light halts, then disappears again. Then it is back once more, some 500 metres from them, still blue, flashing, "twinkling like a star." It remains there for fifteen minutes before making its final departure for that night. They wait on till dawn, but nothing more is seen.

Back at the plantation residence, the investigators continue with the excited discussion. The whole group—all of whom, as already emphasised, are people of above average intellect and education—are agreed that what they have observed is entirely beyond any possible *human* explanation. General Uchoa draws up the report, and the other seven all sign it.

Meanwhile one or two of them go back to the hill to search for any physical evidence, but find nothing. And Sr. Wilson da Silva, now fully calm again and recovered, "guarantees" that the next few nights will bring further manifestations of the phenomenon.

* Evidently the General's group do not read FSR, for, if they did, they would be better informed.

Highlights of the Forthcoming January-February 1973 Issue of Flying Saucer Review

Occupant Symbolism in Phoenician Mythology

Dr. Jaques Vallée

Woodstock UFO Festival—1966

Dr. B. E. Schwarz

UFOs and Occupants Reported in Cape Province—Rosmead tennis court damaged

Charles Bowen

The Little Singing Creatures at Arc-sous-Cicon

Joel Mesnard

UFOs and Anthrapoids

Jerome Clark and Loren Coleman

STILL AVAILABLE . . .

The hard-cover edition of the classic FSR
Special Issue No. 1

THE HUMANOIDS

Studies involving hundreds of landing reports of
UFOs and of their occupants

CONTRIBUTORS INCLUDE

Jacques Vallée Gordon Creighton Aimé Michel
W. T. Powers Coral Lorenzen Donald B. Hanlon

EDITED by Charles Bowen

Neville Spearman Ltd.

Price £1.50 112 Whitfield St., London WC1 8DP

HIGHLY RECOMMENDED . . .

THE IMPORTANT BOOK

by **Dr. J. Allen Hynek**

Professor of Astronomy at Northwestern
University, and for twenty years Civilian Scientific
Consultant on UFO reports to the United States
Air Force:

THE UFO EXPERIENCE: A SCIENTIFIC ENQUIRY

Abelard-Schuman Ltd.
450 Edgware Road
London W2

Price £2.50

HIGHLIGHTS FROM RECENT BACK NUMBERS OF FLYING SAUCER REVIEW. . .

1972

November-December
UFO OVER THE MOORADUC ROAD
by *Judith Magee*

September-October
THE CENNINA LANDING OF 1954
by *Sergio Conti*

July-August
WAS "GOD" AT ABERFAN?
by *F. W. Holiday*

May-June
UFOs WITH MULTIPLE BEAMS OF LIGHT
by *Gordon Creighton*

March-April
**A REMARKABLE CASE FROM MENDOZA,
ARGENTINA**
by *Antonio Baragiola*

January-February
PROJECT DICK
by *Aimé Michel*

1971
November-December
THE STRANGE CASE OF DR. 'X'—Pt. II
by *Aimé Michel*

September-October
MONSTERS AND UFOs
by *F. W. Holiday*

July-August
DEFENESTRATION AT KEMPSEY
by *Eileen Buckle*

**ALL LISTED ABOVE, AND BELOW, STILL
AVAILABLE
MANY EARLIER NUMBERS. ENQUIRIES
WELCOMED**

35p per copy, post paid (90c)

Remittance with order to F.S.R., 21 Cecil Court, Charing Cross Road, London WC2N 4HB, England

. . . AND FROM FSR CASE HISTORIES

1972

Supplement 11, August
A HOT RECEPTION AT FORT BEAUFORT
by *Charles Bowen*

Supplement 10, June
THE STRANGE FORCE THAT MOVED A CAR
GICOFF report

Supplement 9, February
LANDING REPORT FROM DELPHOS
by *Ted Phillips*

1971
Supplement 8, December
CONTACT IN HELSINKI
by *Timo Pyälä*

Supplement 7, October
UFO LANDING AT SOUTH FREMANTLE
by *Nancy L. Wilson*

Supplement 6, August
HORSE ILL AFTER UFO INCIDENT
by *John Magor*

Supplement 5, June
**THE REMARKABLE LANDING AT LAGOA
NEGRA** by *Jader U. Pereira*

Supplement 4, April
OLAF DAVY AND THE WROXHAM UFO
by *Peter Johnson*

Supplement 3, February
HACKNEY FLURRY OF UFOs
by *Sqdn.-Ldr. Alastair Prevost*

1970
Supplement 2, December
LUMINOUS OBJECT FILMED NEAR NEWARK
by *Trevor Whitaker*
Supplement 1 out-of-print

24p per copy, post paid (65c)

Remittance with order to F.S.R. Case Histories, 21 Cecil Court, Charing Cross Road, London WC2N 4NB, England