

HIGHLIGHTS FROM RECENT BACK NUMBERS OF FLYING SAUCER REVIEW...

1986	PRICE	1982	PRICE
Volume 31, No. 6 FOLLOW-UP ON THE BAGSHOT HEATH CLOSE ENCOUNTER	£2.00	Volume 28, No. 4 TELEVISION INTERVIEW WITH ADMIRAL THE LORD HILL-NORTON Timothy Good	£1.15
Volume 31, No. 5 MYSTERY SWIRLED RINGS IN ENGLAND (1985)	£2.00	Volume 28, No. 3 BURNT BY A UFO'S LASER BEAM? Robert Boyd	£1.15
Volume 31, No. 4 THE JINN AND THE DOLMEN: THE MOST AMAZING ABDUCTION CASE YET	£2.00	Volume 28, No. 2 THE UFO CRASH/RETRIEVAL SYNDROME. STATUS REPORT II. Part I. Leonard H. Stringfield	£1.15
Volume 31, No. 3 MORE ON THE "BOOMERANG": "LARGE AS TWO FOOTBALL FIELDS"	£2.00	Volume 28, No. 1 THE RETURN OF THE "CYCLOPES"? Gordon Creighton	£1.15
Volume 31, No. 2 CLOSE ENCOUNTER ON BAGSHOT HEATH	£2.00	1981	
1985		Volume 27, No. 6 THE UFO PHENOMENON: LAUGH, LAUGH, STUDY, STUDY Dr. J. Allen Hynek	£1.15
Volume 31, No. 1 TOP U.S. SCIENTIST ADMITS CRASHED UFOs	£2.00	Volume 27, No. 5 DR. FELIX ZIGEL' AND THE DEVELOPMENT OF UFOLOGY IN RUSSIA — Part III Gordon Creighton (Pts I & II in Vol. 27, Nos 3/4)	£1.15
Volume 30, No. 6 A LANDING AT VARZI, ITALY	£1.50	Volume 27, No. 4 COMMERCIAL JET CREW SIGHTS UNIDENTIFIED OBJECT — Part 1 (Part 2 in Vol. 27/5). Dr. R. F. Haines	£1.15
Volume 30, No. 5 THE SORIA ABDUCTION: PART III	£1.50	Volume 27, No. 3 CE3 REPORT FROM FINLAND J. Kyröläinen & P. Teerikorpi	£1.15
Volume 30, No. 4 THE SORIA ABDUCTION: PART II	£1.50	1980	
Volume 30, No. 3 THE SORIA ABDUCTION: PART I	£1.50	Volume 27, No. 2 A POLICEMAN'S LOT Jenny Randles	£1.00
Volume 30, No. 2 UFO ALERT AT A NATO BASE IN ITALY	£1.50	Volume 27, No. 1 UFOLOGY IN THE U.S.S.R. Nikita A. Schnee	£1.00
Volume 30, No. 1 MORE TELL-TALE PHOTOSTATS	£1.50	Volume 26, No. 6 CONTACT NEAR PYROGOVSKOYE LAKE Nikita A. Schnee (CE3 in U.S.S.R.)	£1.00
1984		Volume 26, No. 5 DID FLYING SAUCERS LAND AT BROADLANDS? (The Mountbatten residence). Desmond Leslie	£1.00
Volume 29, No. 6 MORE ABOUT THE ADVENTURES OF A VERY PECULIAR LIGHTHOUSE	£1.50	Volume 26, No. 4 DIONISIO LLANCA AND THE UFONAUTS Gordon Creighton & Charles Bowen	£1.00
Volume 29, No. 5 U.S. AIR FORCE BASE'S RADAR KNOCKED OUT BY A UFO	£1.50	1979	
Volume 29, No. 4 SOME MULTIPLE SIGHTINGS FROM BLUEBOOK'S FILES Dr. Richard F. Haines, Ph.D. ©1983	£1.50	Volume 26, No. 3 FOUR YOUNG MEN AND A UFO Alleged cow-poaching incident J. Randles & P. Whetnall	£1.00
Volume 29, No. 3 CANADIAN ROCK-BAND ABDUCTED	£1.50	Volume 26, No. 2 SEVEN UFOs SEEN FROM B-36 BOMBER Dr. Richard F. Haines	£1.00
Volume 29, No. 2 A LANDING AND CLOSE ENCOUNTER NEAR ALDERSHOT Omar Fowler	£1.50		
Volume 29, No. 1 A BRIEF ACCOUNT OF THE TRUE NATURE OF THE "UFO ENTITIES"	£1.50		
1983			
Volume 28, No. 6 ARE THE REASONS FOR THE COVER-UP SOLELY SCIENTIFIC? Dr. Pierre Guérin	£1.15		
Volume 28, No. 5 THE LITTLE ORIENTAL AIRMAN Antonio Chiumiento	£1.15		

Remittance with order to: FSR Publications Ltd., (Back Issues), Snodland, Kent ME6 5HJ, England.

FOR BOOKS ON UFOs AND SPACE AGE PUBLICATIONS

Write to
Miss S. R. Stebbing
41 Terminus Drive
Beltinge, Herne Bay,
Kent CT6 6PR

Prices include postage and packing.
Dollar cheques accepted at current ex-
change rate plus \$1.00 bank charge.
Book-lists 34p stamps. Free with orders.
Overseas: international reply coupons of
\$1.00 cash.

Prices and availability subject to change.
Enquiries please include s.a.e.

**UFOs, Ancient
Mysteries, Fortean
literature; Books
and Magazines
bought and sold.**

SAE CATALOGUE.

JOHN TROTTER
11 LAUREL WAY,
LONDON N20 8HR.
Tel. 01-445 4293

FLYING SAUCER REVIEW

PLEASE NOTE NEW PRICES

ANNUAL SUBSCRIPTION (Six issues)

UK and EEC (Common Market) Countries: £12.00 (Single copies: £2.50)

Western Hemisphere: \$US25.00 (Single copies: \$US5.00)

All other countries: £15 (Single copies: £3.00)

All prices include postage by surface mail.

Air Mail extra: for Western Hemisphere: \$US10.00

All other countries: £6.00.

Overseas subscribers should remit by cheque drawn *in Sterling* on a bank in the United Kingdom, or by cheque in US dollars drawn in the USA only, or by International Money Order in Sterling. If remitting by Giro then FSR's account number is 356 3251.

All mail, editorial matter and subscriptions should be addressed to:
The Editor, FSR Publications Ltd., Snodland, Kent ME6 5HJ, England.
Remittances should be made payable to "FSR Publications Ltd."

Artwork: Eve and Contributors



Volume 32, No. 1, 1986



ENORMOUS UFO OVER N.E. SPAIN

See page 2

Editor GORDON CREIGHTON, MA FRGS, FRAS (UK)

Consultants and Correspondents

CHARLES BOWEN, (UK) Former Editor
 (1964-1982)

JONATHAN CAPLAN, MA (UK)
 BILL CHALKER, BSc Hons (AUSTRALIA)
 ANTONIO CHIUMENTO (CISU — ITALY)
 GRAHAM CONWAY (CANADA — BRITISH COLUMBIA)

DR ROBERT F. CREEGAN, MA, PhD (USA)
 IGNACIO DARNAUDE ROJAS-MARCOS (SPAIN)
 PAT DELGADO (UK)

TIM DINSDALE, FRGS (UK)
 PAUL DONG (CHINA)
 ANN DRUFFEL, BA (USA)
 DR P. M. H. EDWARDS, PhD, MA, FTCL, LRAM, ARCM
 (CANADA — VANCOUVER ISLAND & BRITISH COLUMBIA)

LAWRENCE FENWICK (CUFORN — CENTRAL CANADA)
 DR BERNARD E. FINCH, MRCS, LRCP, DCh, FBIS (UK)
 OMAR FOWLER (SIGAP — UK)

TIMOTHY GOOD (UK)
 IRENE GRANCHI (CISNE — BRAZIL)
 DR I. GRATTAN-GUINNESS, MA, MSc, PhD, DSc (UK)
 MARÍA-ÁNGELA THOMAS GUMA (Jane Thomas)
 (SPANISH AMERICA)

DR RICHARD F. HAINES, PhD (USA)
 KHALED HAMSHO (SYRIA & MIDDLE EAST)

DR JAMES A. HARDER, PhD (USA)
 PERCY HENNELL, FIBP (UK)
 AHMAD JAMALUDIN (MALAYSIA & S.E. ASIA)
 JOHN A. KEEL (USA)
 MILOŠ KRMEĽJ (YUGOSLAVIA)
 ANDERS LILJEGREN (ARCHIVES FOR UFO RESEARCH, SWEDEN)
 JUDY MAGEE (AUSTRALIA — VUFORS)
 WILLIAM L. MOORE (FOCUS NEWSLETTER, USA)
 YUSUKE J. MATSUMURA (CBA INTERNATIONAL, JAPAN)

AIMÉ MICHEL (FRANCE)
 DR. RICHARD C. NIEMTZOW, MD, PhD (USA)
 PAUL B. NORMAN (AUSTRALIA — VUFORS)
 DR JEAN-PIERRE PETIT (FRANCE)
 DAVID POWELL (SOUTH AFRICA)
 ANTONIO RIBERA (SPAIN)
 LUIS SCHÖNHERR (AUSTRIA)
 DR BERTHOLD SCHWARZ, MD (USA)
 G. E. SKOV (IGAP, DENMARK)
 DR WILLY SMITH, PhD (UNICAT PROJECT, USA)
 DR R. LEO SPRINKLE PhD (USA)
 DR JACQUES VALLÉE, PhD (USA)
 GENEVIÈVE VANQUELEF (FRANCE — LDLN)
 PAUL WHITEHEAD (UK)
 DR. LEONARD M. WILDER, BDS (Lond.) (UK)
 PROF. R. H. B. WINDER, BSc, CEng, FIMechE (UK)

An international journal devoted to the study of Unidentified Flying Objects and their Occupants.

CONTENTS

Enormous UFO over N.E. Spain
 J.P. Crivillén 2

UFO Chase in Brazil (May 1986)
 Dr Willy Smith, PhD. 6

An "Observing Eye" in the House 8

Close Encounter at Prato di Principato Ultra (Italy)
 Umberto Telarico 9

Project 1946: The Swedish "Ghost Rocket" Documents
 Anders Liljegen 19

Life on Mars, UFOs, SETI, SETA — And Scientist claims The Paranormal is for Real!
 Paul Whitehead 24

Aliens, Laser Beams And Clones
 Paul Whitehead 26

Mail Bag 27

© Flying Saucer Review
 Library of Congress
 copyright FSR Publications
 Limited 1981

Contributions appearing in this magazine do not necessarily reflect its policy and are published without prejudice

For subscription details and address please see foot of page ii of cover

ENIGMA AND MENACE

It is a truism to say, as so many philosophical writers have done, that the vast majority of the human species spend their entire lives in one or other of several levels of "sleep". One of these levels is what we call our ordinary daytime consciousness.

There are entities whose aim and interest it is to keep us permanently in this condition.

Such being the case, the true meaning of most events in human history will escape the notice of the great majority of mankind, who will simply slumber on.

Among such matters that will escape their attention, so that they may go from the cradle to the grave without ever hearing the deeper issues mentioned, are such themes as the great cyclic changes of the Earth itself; the meaning and origins of the Great Wars of this century; the so-called "UFO Phenomenon" (and its relation to those Great Wars!); the perplexing issues of fast-soaring drug-addiction; fast-soaring rape; unnatural sexual practices and deadly new diseases directly associated with them, such as AIDS; hideous and irrational violence of all kinds, including the astounding proliferation of murder, often of mass-murder on an unbelievable scale.

Throughout human history there have unquestionably been severe outbreaks of some of these phenomena, and the few who are not asleep and who therefore see more deeply into the core of things will understand the reasons.

And, finally, there are two more astounding features that are current in our days and that would be the subjects of intense discussion and debate were the humans all awake. These two taboo features are the widespread epidemics of animal-mutilations, performed with a surgical skill that is far beyond even our best surgeons, and the astounding numbers of children that vanish into thin air.

In the United States last year this figure was 1.2 million.

The fact that, both in the USA and here, there are numerous sadists and perverts around, and that their numbers are constantly swelling, still does not begin to explain this perfectly mind-boggling thing about the children.

This, and all the other matters herein touched upon, are subjects upon which we can reflect. (It will be wise to keep to oneself any spectacular conclusions that are reached).

ENORMOUS UFO DETECTED VISUALLY AND ALSO BY RADAR OVER BARCELONA REGION OF N.E. SPAIN ON NIGHT OF NOVEMBER 29/30, 1985.

J.P. Crivillén (C.E.I., BARCELONA)

(Translation from Spanish) from CUADERNOS DE UFOLOGIA IV, 15 (March 1986.)

Sr. Joan Plana Crivillén is a Catalan and, for the benefit of those who are unfamiliar with the Catalan language, we should perhaps explain that *Joan* is not a female name, as it is with us, but = *John* (*Juan* in Castilian Spanish). — EDITOR

THIS sighting started at about 9.30 p.m. on Friday, November 29, 1985, when a sergeant and a constable of the municipal police noticed a big light stationary in the sky over Tarrasa, a small town lying some 33 kms. to the north of Barcelona.

Numerous other local residents also reported the phenomenon to the authorities. Two men at Sant Quirze del Valles observed the light with binoculars and stated that, while to the naked eye it seemed merely like a powerful bluish-white light, with binoculars they had a clear view of an elongated body intensely luminous in its central part and considerably less so at the two ends. Some folk thought at the time that it was a star or maybe Halley's Comet, and so they looked for it again in the same quarter of the sky at the same time next evening, but there was no sign of it.

The Tarrasa Police Headquarters telephoned to the Police (Guardia Urbana) of Barcelona and reported the affair, and at about 10.30pm the latter likewise informed the Air Traffic Control Centre at Barcelona Airport. The traffic controllers on duty were at first unable to pick up anything on their own radarscopes, so they switched off their MTI gear (used for cancelling out fixed echoes). On their radarscopes they then found that they had a fixed echo somewhat north of Tarrasa. In form it was like an extensive blob and it had some unusual features. Its length was estimated at over 200 metres, but as it was not moving, they felt that it might perhaps be caused by the mountainous configuration of the area (San Lorenzo- La Mola Mountains, altitude 1,000 metres).

The radar employed in picking up this blob was an ASR-7 of the so-called GCA primary approximation type, located on the runways of the Barcelona Airport. This is what is known in Spanish as a "TAR" radar (terminal area radar) working in ultra-high frequencies, and with a maximum range of some 110 kms. It merely gives the distance of a target-echo, and its direction, but being of *plane type*, it is unable to give altitudes. In the region in question this particular radar is employed to pick up aircraft flying at between 600 metres and 12,000 metres.

Upon receipt of the alert, the Barcelona Police at once informed the TV-3 television station (*Independent Catalan Television*) who at once despatched a team to Tarrasa. Arriving there, they were joined by units of the Tarrasa Police, and arranged to take video-film (BETA CAM) of the powerful light stationary over the town, its apparent size about three or four times that of a normal star. (The TV team also tried to film some of the stars for purposes of comparison, but were unsuccessful, their camera being unable to register the much fainter luminosity of the stars).

In the meantime, Barcelona Air Traffic Control directed several commercial aircraft towards the Sabadell-Tarrasa region. These were probably a *DC-9*, flight 13-799; a *Boeing -727*, flight IB-899; and a *DC-9*, flight IB-901, all belonging to the Iberia Air Lines and all three bound for Madrid from Barcelona.

The pilots of all three of these aircraft reported that they could see absolutely nothing in the area of sky indicated. The weather conditions at the time, as shown by the Traffic Control's own instruments and by the

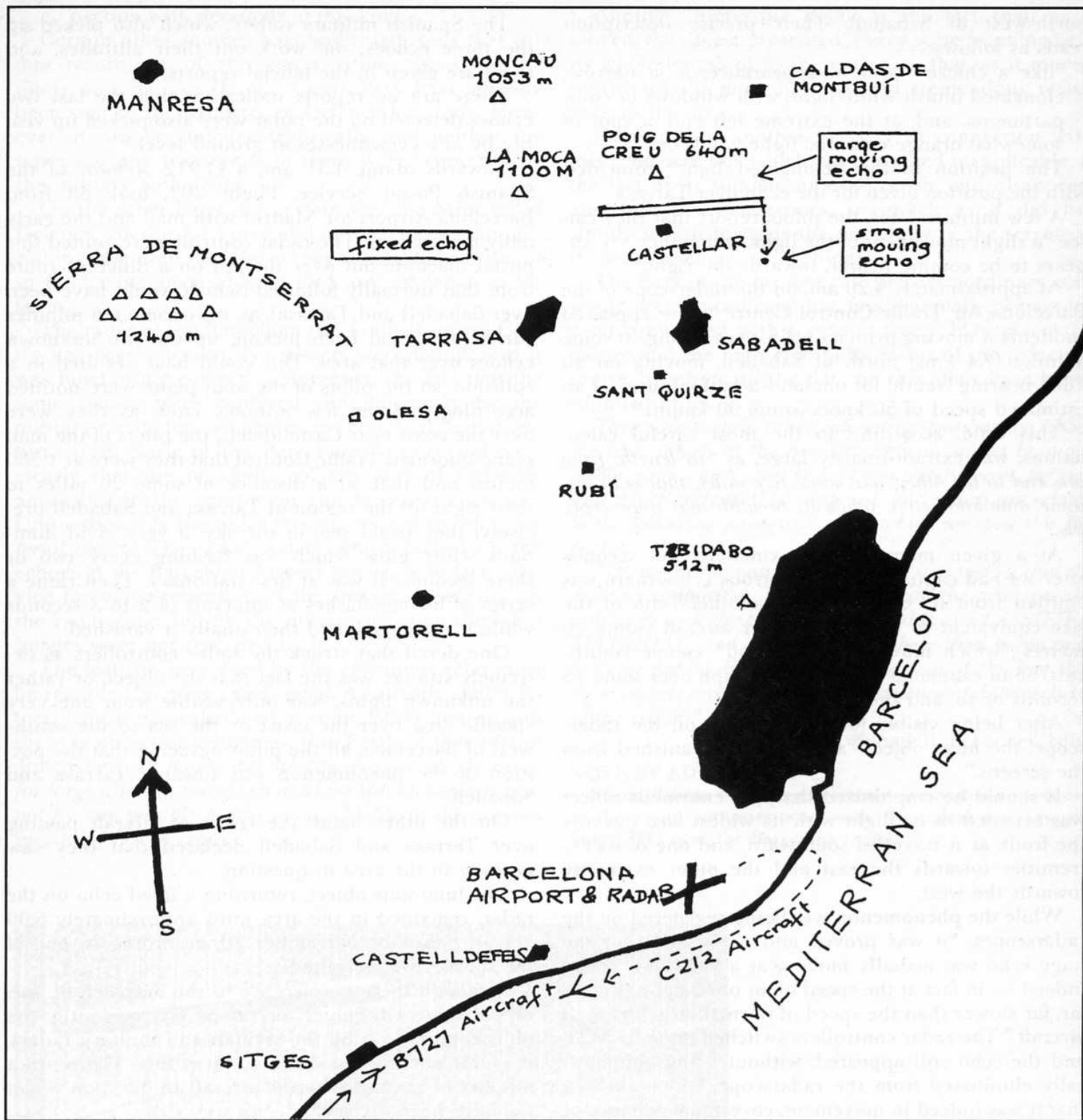

Map of Barcelona area.

instruments of the three aircraft, were as follows:-

Wind: from N. 8 to 10 knots (15-18 kmph).

Atmosphere: clear.

Visibility: excellent.

Temperature: normal, and slightly chilly (under 15°).

Sky: totally clear and full of stars.

It is consequently established that there were no temperature inversions, and there were also no *sonde* balloons in the region.

At 1.30 am, an Iberia Air Lines *Boeing 727*, Flight No. IB-064, coming from Tenerife (Canary Islands) was near Sitges (on the Spanish coast south-west of Barcelona), flying at 2,000 metres and heading for Barcelona Airport. The Traffic Control Centre requested the pilots of this craft to look at 10° or so to their left and report if they saw anything. Shortly afterwards the pilots replied that they could see a linear-shaped soft blue light, not very bright, to the

north-west of Sabadell. Their precise description reads as follows:—

“like a chicken-farm in appearance, ie, a narrow, elongated bluish-white light, with windows or compartments, and, at the extreme left end, a spot of somewhat orange-coloured light stands out.”

The position of this “elongated light” coincided with the position given for the echo over Tarrasa.

A few minutes later, the pilots report that they can see “a slight movement of the light, which they say appears to be coming nearer, towards the right.”

At approximately 4.20 am, on the radarscope of the Barcelona Air Traffic Control Centre “there appeared suddenly a moving primary echo, very strong, at some 4 miles (7.4 kms) north of Sabadell, moving on an 180° bearing (south) for one-and-a-half minutes, at an estimated speed of 50 knots (some 90 kmph).”

This echo, according to the most careful calculations, was extraordinarily large, as “*its length, from one end to the other, was some five miles, that is to say, some nine kilometres, while its breadth was imperceptible.*”

At a given moment, approximately “50 seconds after we had captured this monstrous echo, there was emitted from its extreme right another echo of the size equivalent to that of a fighter aircraft (some 20 metres), which moved off on a 150° course (south-east) at an estimated speed of 900 kmph over some 15 seconds or so, and then vanished.”

After being visible for 1½ minutes on the radarscope, the huge object “also suddenly vanished from the screens.”

It should be emphasised that this enormous object was oriented in its flight with its widest face towards the front, as it travelled southward, and one of its extremities towards the east and the other extremity towards the west.

While the phenomenon was being registered on the radarscopes, “it was proved and confirmed that the huge echo was actually moving at a very slow speed indeed — in fact at the speed of an ultra-light aircraft, far, far slower than the speed of normal large or small aircraft.” The radar controllers switched on their MTI, and the echo still appeared, without being automatically eliminated from the radarscope, which showed that it was indeed in movement, covering a distance of approximately 2,250 metres, which brought it to 5.2 kms. to the north of Sabadell. The small echo that had detached itself from the main one covered about 4 kms. in its observed 15 seconds of flight, and then disappeared towards the north-west of Sabadell.

Apparently the Barcelona Air Traffic Control Centre were unable to establish the altitude of the enormous echo or of the smaller one that came from it, although from the mountainous configuration of the terrain round about it would seem that their altitude must have been greater than 1,000 or 1,500 metres. As for the fixed echo, that must have been at a height of several thousands of metres.

The Spanish military radars, which also picked up the three echoes, *did* work out their altitudes, and these are given in the official reports.

There are no reports indicating that the last two echoes detected on the radar were also picked up visibly by any eyewitnesses at ground-level.*

Towards about 4.31 am, a C-212 *Aviocar* of the Spanish Postal Service, Flight 302, took off from Barcelona Airport for Madrid with mail and the early daily newspapers. The radar controllers re-routed this postal machine out over the sea on a different route from that normally followed (which would have been over Sabadell and Tarrasa), as, only some ten minutes earlier, they had been picking up the two unknown echoes over that area. This could have resulted in a collision, so the pilots of the mail plane were notified accordingly. Some few minutes later, as they were over the coast near Castelldefels, the pilots of the mail plane informed Traffic Control that they were at 1,500 metres and that, at a distance of some 20 miles to their right (in the region of Tarrasa and Sabadell precisely) they could see, in the sky, a very vivid luminous white glow which was flashing every two or three seconds. It was at first stationary. Then came a series of further flashes at intervals of 2 to 3 seconds while it zigzagged, and then finally it vanished.

One detail that struck the radar controllers as extremely strange was the fact that the object, or rather the unknown lights, was only visible from one very specific area over the coast or the sea to the south-west of Barcelona, all the pilots agreeing that the position of the phenomenon was towards Tarrasa and Sabadell.

On the other hand, the crews of aircraft passing over Tarrasa and Sabadell declared that they saw nothing in the area in question.

The luminous object, returning a fixed echo on the radar, remained in the area until approximately 6.00 am on Saturday, November 30, according to one of the sources we consulted.

Although there is reference to the despatch of one, or possibly two, fighter aircraft to try to identify the objects picked up by the civilian and military radars, it is not possible for us to confirm this. There are a number of reasons why the aircraft in question *might not* have been dispatched:—

- a) The echoes did not enter Spanish air-space from outside it, since they were already in it.
- b) The detection period for the two moving echoes was very brief.
- c) In view of the enormous size of one of the echoes, the idea that it could possibly have been a hostile plane, or, for that matter, any sort of conventional aircraft, was totally ruled out.
- d) It seems that for quite some time past, Spanish military aircraft have been taking off under ‘alert conditions’ only very rarely. In any case, whether or not aircraft did take off, there are always serious aspects to be considered in con-

nection with decisions of this kind.

Certain other sources have indicated to us that the tape-recordings of the conversations between the pilots and the Air Traffic Controllers have already been sent to the Ministry of Defence for study. However, it can be stated categorically that neither the tapes nor any transcripts of them were requested by the military authorities.

On the other hand it is certain that the Ministry of Defence, via the Air Force, did at once initiate an official investigation into the events of that night, without so far having been able to find any explanation for them.

The radar of the Barcelona Air Traffic Control Centre has been checked. No defects were found, and it was functioning correctly. Moreover, the fact that the same echoes were captured simultaneously by the military radars too, which possess certain different features from those of the Barcelona Airport, indicates clearly that the possibility of any sort of technical anomalies in the equipment can be ruled right out. Unquestionably the radar returns related to *solid, material objects*. The radar system which picked up the echoes at the Barcelona Airport possesses in fact a device for video-recording of the images appearing on the radarscope, but on the present occasion the UFO images were not recorded by it.

The features presented by the enormous echo must be regarded as quite exceptional. As already stated, its total length was calculated at some 9,000 metres, and there is no aerial vehicle on this Earth of that sort of dimensions. *Its horizontal velocity was outside the usual for large aircraft, inasmuch as at 90 kph an aircraft cannot by any possible means remain stable in the air and inevitably has to crash.*

Another interesting detail is the fact that, as it moved, the object presented a very wide front, namely its whole length of 9,000 metres, so that, as it moved southwards, it must have offered tremendous resistance to the air.

Furthermore, another mystery in connection with this echo, and one which has remained inexplicable, is the fact of its sudden appearance on, and disappearance off, the radarscopes, inasmuch as it did not simply vanish towards the periphery of the screen as is the normal course of things.

The facts in the present case are extraordinary, and would seem to indicate that, fundamentally, we are indeed confronted with a case of true UFOs, given the nature and the high credibility status of the principal source by whom all the data on this affair have been supplied to us.

There are certain other interesting features too about the case, which at the present moment cannot be made public, and which must be kept completely secret, for reasons which may well be supposed, and which are related to the following paragraph with which we close this Report:-

"Owing to the nature of the facts, it is logical that the military authorities, having secured all the principal details of this incident, have catalogued it as CLASSIFIED MATERIAL, and aim to see that there shall be no publicity or public discussion of it, in view of the fact that these reports involve the national defence and the security of the realm."

Sabadell, February 1986

NOTE BY EDITOR, FSR

*Toni Ribera telephoned recently to say that he was one of the many witnesses who, with the naked eye, saw the huge UFO over the Barcelona region.

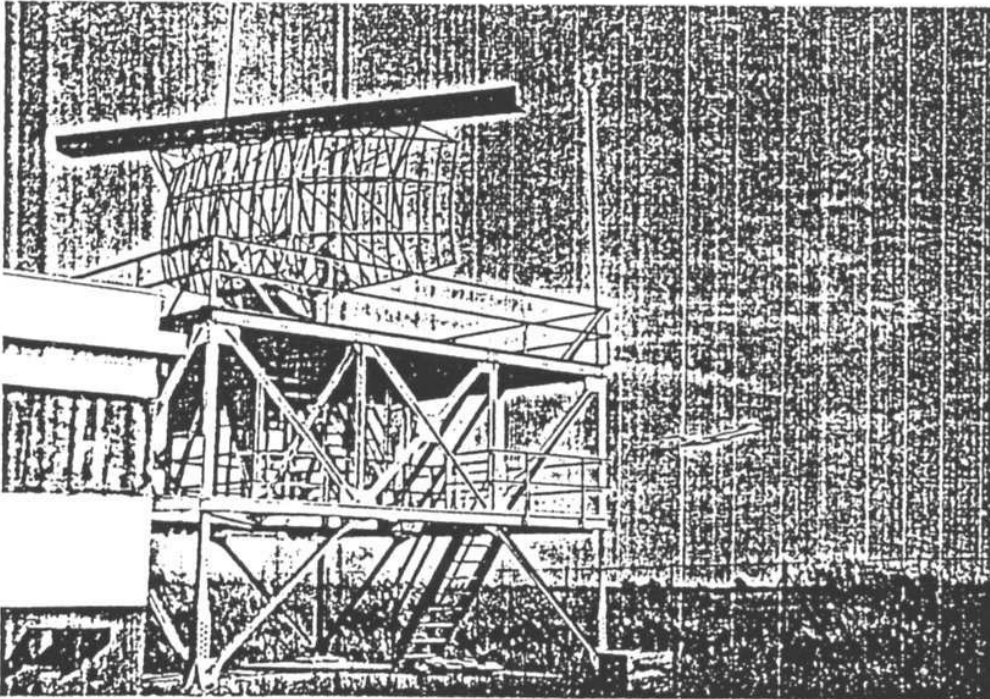

The antenna of the ASR-7 radar at Barcelona Airport.

UFO CHASE IN BRAZIL (MAY 1986)

Dr Willy Smith, Ph.D.

(Unicat Project). Consultant to FSR

Dr Willy Smith, who lives in Longwood, Florida, is another of the many new and valued Consultants who are rallying to FSR, and we welcome him most warmly!

The Brazilian "flap" which he covers in this report is, of course, the one which was described by the more oafish elements of the American and British press as involving "Pingpong Balls over Brazil!" Needless to say, as Dr Willy Smith emphasises, we have so far found no evidence whatsoever that at any moment any Brazilian referred to "pingpong balls". But, as we know, that sort of term is always calculated to be a sure-fire way of ridiculing our subject and making us all look like a bunch of fools. — EDITOR

Introduction

AFTER maintaining a low profile for a period of several years, UFOs briefly regained the world headlines following an incident in Brazilian air space during the night of May 19, 1986.

In spite of the large amount of clippings received from UNICAT correspondents in Brazil and Argentina, as well as reprints of news items that appeared in American newspapers, I find it difficult to organize the information in a coherent narrative. The different Brazilian newspapers and the statements of Government officials provide somewhat contradictory versions of the events, but it is clear that something out of the ordinary occurred, enough to shake the complacency of the authorities.

* * * *

Sequence of events

The night of May 19, 1986, a Monday, was clear and with good visibility, devoid of heavy clouds that could affect radar.

An executive plane, a Brazilian-made two-engine *Xingu* owned by EMBRAER (Emprêsa Brasileira de Aeronáutica), was en route from Brasília to São José dos Campos (near São Paulo). While starting its descent, it was alerted by the São Paulo radar control that an unknown object was in the area. The presence of this unknown object was confirmed shortly by the radar at Brasília.¹

In the pilot seat of the *Xingu* was a well known man: Colonel Ozires Silva, former president of EMBRAER, who had just been appointed head of PETROBRAS, the Brazilian state-owned oil company. According to the official version, Col. Silvas was the first to spot visually the unidentified object as a "dancing point in the sky".² The time was 21:10.⁸

Seated beside Ozires Silva was a civilian pilot for EMBRAER: Commander Alcir Pereira da Silva, age 37, with more than 6000 hours of flying time. In his statement to the press,¹ Comm. Alcir Pereira da Silva



UFO Chase in Brazil.

indicated that when the *Xingu* had descended to 2000 ft., the pilots perceived a strong light and turned the plane in its direction. The light is described as "brighter than a star, emitting a constant red-orange light" and also as being on for 10-15 seconds, then off, only to reappear at a different location.¹ Whatever the case was, the pilots were very soon discouraged, and abandoned the chase after about 30 minutes.

By that time, the Brazilian Defense Center (CINDACTA = Centro Integrado de Defesa Aérea e Controle de Tráfego Aéreo) which apparently controls all air traffic, was on full alert, as the radar screens in the vicinity of São José dos Campos and nearby São Paulo were saturated and all air traffic had been interrupted.²

Only minutes after the appearance of the unknown objects on the radar screens, jets were scrambled from

two Air Force bases (see map): Santa Cruz, in the State of São Paulo, and Anápolis, near Brasília. Although the number of jet fighters scrambled, as well as the number of UFOs that were detected, is variable depending on the spokesman, the indisputable fact is that planes were dispatched, attempted to approach the lights, and failed.

The UFOs had initially appeared over a mountainous region between the states of Rio de Janeiro and Minas Gerais, known as the Serra da Mantiqueira.² The incident terminated near midnight as suddenly as it had started, with the UFO disappearing simultaneously from radar and from visual observation after moving toward the ocean beyond the Brazilian coast. The duration of the sighting was close to three hours.

* * * *

The pilots' accounts

The Brazilian Air Force allowed the pilots to have a press conference in which they freely expressed their versions of the events of May 19. According to our correspondent in Rio, Mrs Irene Granchi, the 7 pilots and 3 radar controllers that participated in the incidents appeared on television.⁴

We summarize their statements from the information received from Mrs Granchi, as well as from the version published by the prestigious newspaper O GLOBO.³

All of the seven pilots were military, except the already named Comm. Alcir Pereira da Silva.

Three *F-5E* jets were scrambled from the Santa Cruz AFB near São Paulo, two of them at 22:23 and the third at 22:55. In addition, three *Mirage III* jet fighters were scrambled from the Anápolis AFB at 22:50,⁸ but only one had an effective contact. The time of the actual contacts has been established as between 22:55 and 23:20.⁸

The pilot of one of the *F-5Es* was Lt. Kleber Caldas Marinho, aged 25. Following the instructions of the radar controller, he vectored his plane to a target 35 miles distant, but was unable to close in. The radar control in Brasília informed him at this point that the target was approaching him rapidly. However, the pilot didn't see anything, and in his own words, "*one gets scared of what one sees, and I saw nothing*". But later in the chase, he finally obtained a visual contact. As verified by both the ground radar and the on-board radar, the target was at a distance of 35 miles, but when the pilot tried to narrow the gap it was "like attempting to reach a point at infinity", in spite of his 1000 km/hr (625 mph) speed. As his fuel was getting low, he returned to the Santa Cruz Air Force Base.³ He describes the target as a reddish light, very intense, which changed colours when the chase was aborted, first to white, then to green and to red again.³

The pilot of the second *F-5E*, Capt. Marcio Jordão,

age 29, was luckier, as he was able to reduce the distance to the target to 12 miles. He describes the UFO as a very strong light of continuous intensity, and changing colours continuously from white to green. Capt. Jordão broke off the contact when the object moved over the sea beyond the 200 mile limit from Santa Cruz.³

Of the three *Mirages* scrambled from the Anápolis Base, only one was able to establish actual contact. It was piloted by Capt. Armindo Souza Viriato de Freitas, age 30, whose statements we transcribe:^{4,8}

"I was warned by ground control that there were several targets ahead of me, at a distance of 20 miles and ranging in number from 10 to 13. I was also advised that the targets were approaching my plane, and finally that they were following me at a distance of 2 miles (*sic*). I had to lower my plane, as the lights had descended, but from then on they climbed vertically. This was my only visual contact, but I could see them in my radar at a distance of 12 miles." The radar controller at the Anápolis AFB was Lt. Hugo Nunes Freitas and he advised Capt. Viriato that he had several targets behind his plane, six to one side and seven to the other.

According to O GLOBO,³ Capt. Viriato added that the targets made 80 degree turns (possibly 180 degrees was meant) and that he could not manage to have a visual contact right ahead of his plane. "No plane I know can make turns like that at 1000 km/hr," he concluded.

One of the traffic controllers, Lt. Valdecir Fernando Coelho, stated: "In my 14 years of experience as a radar operator, I never saw anything like this." ... Familiar, isn't it?

At the close of the press meeting, and immediately following the pilots' reports, the Air Ministry declared that no further reports are to be expected on the incidents until the special commission appointed to investigate the events has reached a conclusion.

* * * *

The Air Minister

Some unusual and out of character developments must be pointed out. The Air Minister, Brigadier Otávio Júlio Moreira Lima, after informing the President of Brazil, José Sarney, of the incident, proceeded to inform the press that the radar screen of CINDACTA in São Paulo had been saturated, that jets had been scrambled, and that visual-radar contacts had been established with "balls of light of multiple colours".

This is the first time that a high-ranking officer of the air force of any nation has come forward and admitted the presence of unidentified objects, and moreover, that intercept attempts had failed.^{2,5}

In addition, the Air Minister carried on his press conference in a semi-humorous tone, indicating that

he "always wanted to see a UFO as a child", but adding "that radar is not subject to optical illusions. The radar echoes are due to solid objects or to massive clouds, which were not present that night."

Strangely enough, the Air Minister, Brig. Moreira Lima, did not seem concerned about this unchecked penetration of the Brazilian air space, but was rather proud of the prompt response of the Air Force to an alert.⁷

According to CLARÍN,² the decision to release the news to the public was made personally by President Sarney, another first.

* * * *

Conclusions

Although their number is uncertain, numerous UFOs were observed visually and detected by both ground and airborne radars. The episode lasted for near three hours, but the only concrete information is that they were balls of light of different and changing colours, which the jet fighters could not really approach. As in many other cases, the initiation and termination of the incident were sudden and unexpected.

Weather was good, a clear night without clouds, so that radar echoes remain unexplained. The number of echoes was very large, enough to saturate the radar screens and, according to the Air Minister, corresponded to solid targets.

Nowhere in the original *Brazilian* newspaper clippings have I found a direct quote about the "pingpong balls" mentioned in the American press. CLARÍN of Buenos Aires² stated that the UFOs were described alternatively as stars, football balls, or "pingpong balls".

As for the speeds of the UFOs, only two specific quotes were made by the Brazilian press. The first refers to the statements made by Colonel Ozires Silva, who is an aeronautical engineer by training, commenting on his attempt to approach the lights. He indicated that the maximum speed of his plane was 400 km/hr (250mph), while the lights were apparently

moving at a speed of 1500 km/hr (937 mph).⁶

The second concrete mention of speeds was made by Major Ney Cerqueira, head of CINDACTA, who actively participated in the tracking operations. According to Maj. Cerqueira, "due to technical limitations in the radar equipment" the speeds could not be determined with precision. "The speeds detected varied in an interval of 5 to 10 minutes from 150 knots/hr to 800 knots/hr".⁵ In miles per hour, this corresponds to a range of 173 to 921 mph, and matches well with the information that jets with speeds of 1000 km/hr (625 mph) were unable to close on the lights.

The sighting started, according to the Air Ministry, at 20:50 and ended about midnight, having thus a total duration of 3 hours.⁸ Finally, the number of UFOs has been quoted by the media as between 13 and 21. The Air Minister placed the number at 20.⁷

Since most of the information on which this report is based was obtained from newspaper clippings, usually a highly unreliable source, it is necessary to emphasize that in this particular instance the media did a very faithful reporting job. Most of the details were released at the press conference in which the pilots related their experiences and were directly questioned by the reporters. The information written in the different papers is consistent and accurate. In addition, the Air Ministry released further information as a chronology of the events.⁸ Altogether, then, we are satisfied that the incident occurred as narrated.

* * * *

REFERENCES

- (1) JORNAL DO BRASIL, May 23, 1986.
- (2) CLARÍN, Buenos Aires, May 23, 1986.
- (3) O GLOBO, May 24, 1986.
- (4) Irene Granchi (UNICAT Project correspondent in Rio de Janeiro), private communication.
- (5) JORNAL DO BRASIL, May 22, 1986.
- (6) O DIA, May 23, 1986.
- (7) O DIA, May 22, 1986.
- (8) FÓLHA DE S. PAULO, May 24, 1986.

AN "OBSERVING EYE" IN THE HOUSE

THE Spanish mimeographed bulletin *Cuadernos de Ufologia*, No. 4/15, issued in March 1986, contains an account of a small object seen inside a house, in Spain, in August 1972.

A lady, Amparo Gascón Valldecabrés, who was a twelve-year-old girl at the time, has only recently revealed the incident to her brother, Juan Marcos Gascón Valldecabrés (author of the present account) and others who, with him, were at that time members of the Valencia UFO Investigation Group (AVIU).

The witness was staying during her holidays with her uncle and aunt who had rented a ground-floor apartment in Losa del Obispo, a village lying some 50 kilometres to the north-east of Valencia. Valencia lies on the east coast of Spain, at 39 27 N., O. 23 W.

The witness states that, one night during the month of August 1972, at about 3.00 a.m., while staying in the house in question, she awoke and went to the toilet and, in the corridor outside her room, was confronted with an eye-shaped or almond-shaped object,

of the colour of glowing embers, which was stationary in the air, at a height of about two metres from the floor and half a metre from the ceiling. She felt that the object was "observing" her. She describes it as about five centimetres long and three centimetres thick. She detected no sound from it, nor smell, nor any sensation of heat or cold. Her first impression was one of mere surprise, but as she stood there and watched the object, still motionless, she became scared. After a few minutes, she retreated into her bedroom and spent an anxious and sleepless night fearing that it would come in, but it did not, and when she got up next morning, the object was gone. After much hesitation, she decided not to tell her parents, since they "would perhaps not have believed me, or

would have laughed at me." The only person whom she told about it was her older sister Inés, but her brother only chanced to hear about it long afterwards — in 1980.

A very similar sort of thing, seen in a house in Rio de Janeiro, Brazil, was reported by Dr W. Buhler in 1962, and Jennie Zeidman has given us another case, with almost identical features, from Ohio, U.S.A., in 1979.

NOTES AND REFERENCES

- (1) Jennie Zeidman: *The Thing that Got into the House*. In FSR 28/2 (1982), page 9.
- (2) Dr W. Buhler: *A Similar Case in Brazil in 1962?* In FSR 28/2 (1982), page 10.

CLOSE ENCOUNTER AT PRATO DI PRINCIPATO ULTRA (ITALY), OCTOBER 1984

Umberto Telarico

(Translation from French)

In FSR30/4 we gave a brief, fifteen-line account of this case, in Signor Edoardo Russo's *Italian Update 1984*. Edoardo Russo is the Foreign Liaison Editor for C.U.N., the Italian National Ufological Centre. The March/April 1986 issue of *Lumières Dans La Nuit* (No. 261/262), which we have recently received, contains a long and most detailed account of this case, written originally by Umberto Telarico and rendered into French by Maria Toffano. The material published in FSR is always at the disposal of our good friends in France and Italy and, on the same basis, we take the liberty now of translating Maria Toffano's French version into English for our readers.

The date of the episode was October 8, 1984. As will be seen, there are certain discrepancies in the two versions. We can, however, take it as certain that this later and very thorough investigation has provided the accurate story.

Our thanks and congratulations to CUN in Italy and Jacques Scornaux and to LDLN in France for this most interesting piece of work, and also to a second Italian group, the "SOLARIS" UFO Investigation Group in Naples, who conducted their own supplementary enquiry. The case occurred in a country area north-east of Naples in Southern Italy. — EDITOR

PARTICIPANTS: Q: CUN Investigator Umberto Telarico
A: Eyewitness of episode, Giuseppe Cocozza
C: Accompanying CUN Investigators

* * * * *

Q: Well now, Don Peppino. Just pretend that there's nobody else here in this room with us. It is the morning of October 8 of this year, and you are going out to your alfalfa (lucerne) field. Recall in a loud, clear voice what happened.

A: This is what happened. I had been alone in the

house, as my wife and my son had gone to the funeral of my mother-in-law. I didn't go with them myself as I had a very painful leg, due to arthritis. So I decided to go and get some fodder for my cow, which was in the byre. While I was getting the lucerne, I suddenly noticed a man — an individual — who seemed to be a stranger. I stood looking at him for a bit, and thinking, for I had never seen anybody who looked like that. And then, as I looked at him, I said to myself: why, this chap's a madman. Just look — what a madman!

I had a side-view of him. Then I had the idea of coughing, so as to get him to turn round. When he heard me cough, the man turned round

towards me and then I saw that he had a pair of a sort of aluminium spectacles in front of his eyes.

- Q: What was his height?
A: About 1 metre 20, or 1 metre 30.
Q: What distance was he from you?
A: About 20 metres.
Q: But what was he doing?
A: In his hand he was holding a little forked rod, with two teeth, and exploring the ground, swinging this little fork. When he heard me cough, he turned round and looked at me for a few seconds. He took three or four steps, and then began to give off sparks from both sides, like from an electric welder, and from the other side he shot out flames, and me, well, when I saw that fire I got scared, and I stepped backwards, I retreated, very softly. Two minutes later, as I was stepping back, I saw a box take off, very fast. It travelled three or four hundred metres in a second, going absolutely straight. Then it landed on the ground again, further on, beyond a wood.
- Q: And approximately how big was this "box"?
A: It could have been about two metres long, shall we say, and one metre thirty, or one metre forty cms. wide.
- Q: Was there anything strange about the thing, or was it a normal "box"?
A: No. On top of the box, I noticed that there was what seemed to be like a sort of dish, with two supports holding it.
- Q: Did you hear any noise, any sounds?
A: No, I heard nothing. The only sound I heard was from *him* when he gave out the sparks and made the sound like "tra-tra-tra".
- Q: Now, let us discuss this individual, that you saw. You have said that he had a round head, like us. Was it larger than ours?
A: It was like our head. But it isn't certain that it *was* a head.
- Q: Did he have a neck?
A: Yes.
- Q: Was his body thick-set?
A: Yes. He was very strongly built, but of small height: one metre twenty centimetres, or one metre thirty...
- Q: Did you notice any limbs, like arms, legs?
A: Oh yes, arms and legs. He was bending over while he was doing that. (*Note by Author: the entity raised one leg, and then the other, several times, and bending the knees, as he manipulated his instrument.*)
- Q: Was the length of his arms normal in relation to his height?
A: Yes.
- Q: Did you notice whether he had fingers like ours, or whether they were different?
A: I didn't see them. He had the forked rod in his hand. It was of the same colour. (*Note by Author:*

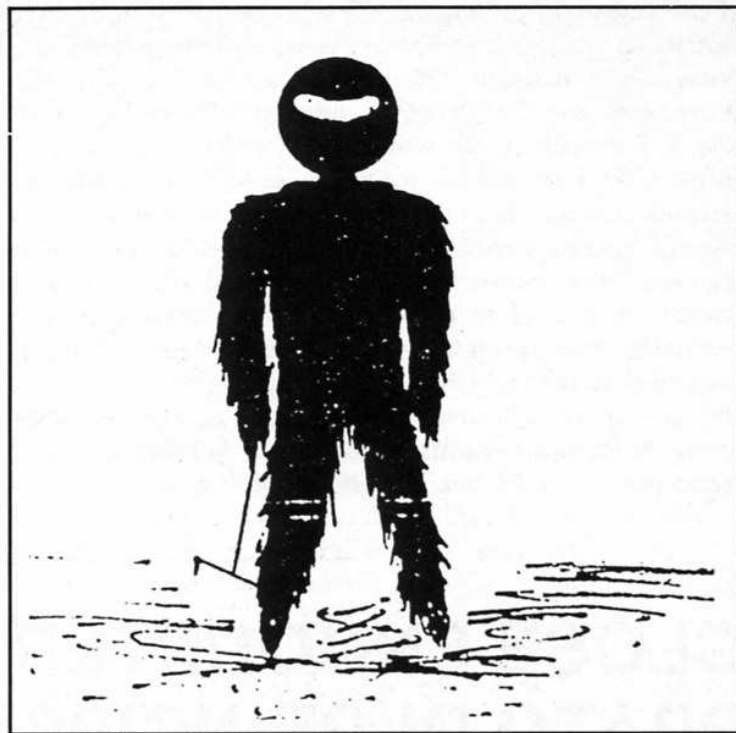

Fig. 1 Frontal view of the entity, holding his forked rod.

- of the same colour as his body, which was of a dark hue, covered with long hair.)
- C: Was he holding it by one hand only?
A: In one hand at first, while he was doing that. After that, I coughed...
- Q: What did you notice that he had on his back?
A: On his back he had a sort of box from which a lead ran to the nape of his neck.
- Q: And were there other tubes?
A: Yes, there was another lead there (*indicates the spot on a sketch drawn by the Investigator*) which also went across his back under the box. Then it seems to me that here (*he indicates the protuberance on the site of the mouth*) there was a small tube that was attached to his back, somewhere near the box.
- Q: You saw him from the back...
A: Yes, I saw it when he turned round.
- Q: What was the box like? Was it made in one piece?
A: Yes.
- Q: Did it have angles, or was it round?
A: It was square.
- Q: Like a rucksack?
A: Yes — that's it. Like a rucksack.
- Q: And, tell us, Don Peppino, what did he have on the front of him?
A: In front, all I saw was that he was hairy, like a goat.
- Q: Was the hair long?
A: Yes — long. About 15 cms. long.
- Q: Over the whole body?
A: Yes, yes. Down to here (*indicating the feet*). And

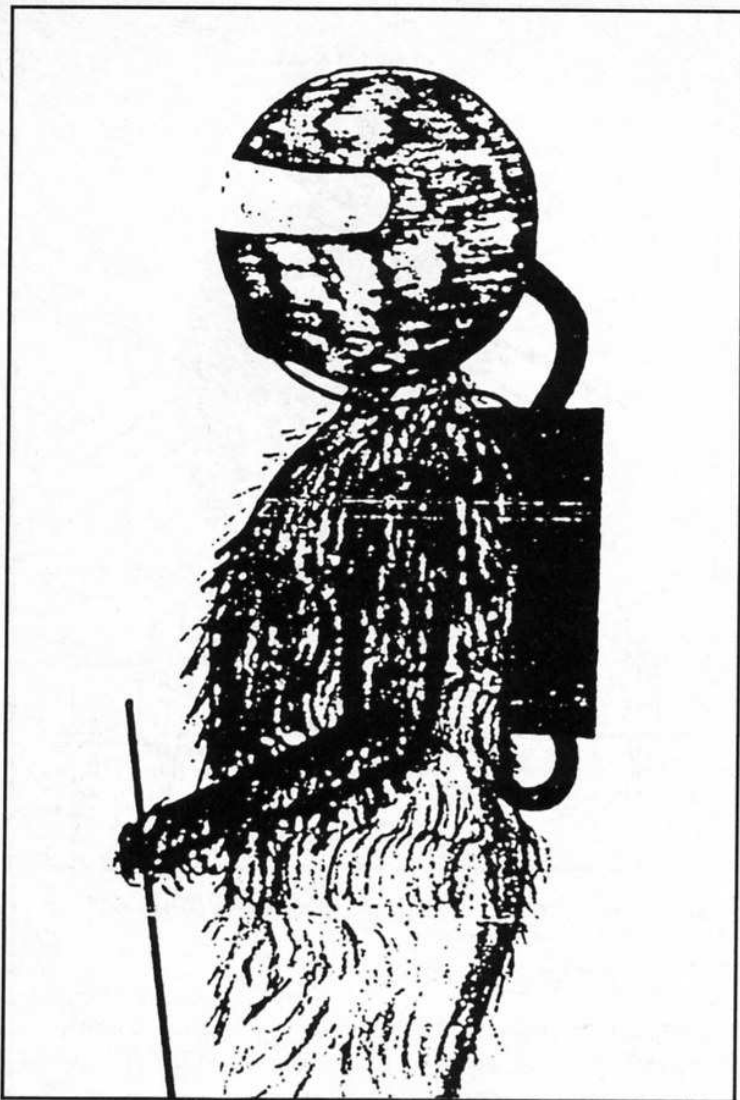

Fig. 2 Profile view of the entity, showing position of a possible small tube between the mouth and the pack on the back.

there he had hooves, like the hooves of a donkey or a goat.

Q: What did he have in front of his face?

A: In front of his eyes I saw spectacles with a vizor of, how should I put it — a sort of aluminium crystal.

Q: Of what shape was it?

A: It went right across to the ears (*indicating on his own face*).

(The Investigator at this point shows him a sketch of the entity's "helmet" and the witness sketches roughly on it the shape of the "spectacles".)

Q: Of what colour was his "head"?

A: Still all the same colour ... dark brown.

Q: And what was it, Don Peppino, that came out from the sides of the pack on his back?

A: No. It was from the chap's sides. He gave out flashes of the same colour as from a soldering-iron.

Q: Did the flames come out irregularly?

A: No. It was continuous. He shot out flames without stopping.

Q: However, he wasn't emitting flames when you first saw him?

A: No. But I'm just telling you what I saw.

Q: So, when he turned round and saw you...

A: I coughed, and the chap turned round. I watched him for a moment, and then he took two or three steps backward and began to make this "zrou, zrou, zrou" sound, shooting out flames from both sides.

Q: Did he turn round because he was about to depart?

A: Yes. He turned towards me, and he saw me...

Q: And he started to shoot out flames from his sides. Were the flames very long?

A: Maybe not as much as a metre, but at least 70-80 cms. of flame, shooting out on the right and left sides of him.

Q: Flames of what colour?

A: Of exactly the same colour as when you use a soldering-iron ... violet-coloured, like you get in arc-welding with oxygen.

C: Are you sure the flames did not come from the pack on his back?

A: No. No. From his two sides (*indicates his own haunches*).

C: Were there tubes, or holes, there?

A: Ah, well, that — I didn't notice that...

C: But they came in bursts, like this...

A: Yes, in bursts. "*Foumm, foumm, foumm*" ... And then, after that, "*zrou, zrou, zrou, zrou, zrou*". That was the noise

C: And his feet?

A: Maybe of aluminium ... I don't know...

C: And the flames ... were they continuous?

A: Continuous all the time ... fixed, no fire, just these jets.

C: Maybe it was just *light*, and you had the impression that it was flame?

A: No. There were sparks.

Q: When he saw you, he didn't start to run?

A: No. He walked fast, but with short steps...

Q: He never turned back towards you?

A: I watched him, right up to that moment, but once he had passed behind the tree, I lost sight of him ... and I tried to see him ... and then I saw this sort of box taking off.

C: How did he walk, how did he move?

A: Just like a normal person ... but he was too ... his steps were too fast, but short, not the way people would walk.

C: Should we say — like a child?

A: Well, yes, that's right...

C: His gait was in proportion to his height, would you say?

A: He walked quickly, but his steps were small because he was small himself ... he didn't have legs like us ... you see what I mean?

Q: And while he was holding this instrument, he was bending his knees?

A: Yes.

Q: Then, after that, what happened, Don Peppino?

AL: Well then, after that, I saw this sort of box taking off. In one second, it was behind the wood, and after that I saw nothing more.

Q: So, what did you do after that?

A: I went back home, and I got my gun, and I put some cartridges in. I took out the small cartridges and put some big ones in instead. And then I went back there. Showing myself as little as possible. So as to see more or less whether ... I returned more or less to the spot where it had happened. I found footprints on the ground. No, not footprints, but rather, a sort of hoof-marks ... so queer, I didn't know whether it was from a horse, a horseshoe ... or ... anyway, in brief, truly very queer little hoof-marks. Then, having in the meantime pushed on a bit further, I saw this outline there on the ground (the marks left by the UFO) as though something had landed there. I couldn't understand what it could be ... I'd seen that flying box that had landed there, but me, well, I couldn't make out what that was ...

Q: So then what did you do next?

A: What did I do? Well, I returned home. There was nobody in the house. When my son Michele returned, I sent him over to see the Carabinieri (Police) at Pratola Serra. But by the evening, nobody had come, so I sent another of my sons over to them and told him to say to them: "Come ... because I know what I have seen ... And, if you don't, I will go somewhere else. And if tomorrow something serious happens ..." Well anyway, the Carabinieri did come that evening, and they even went out to the spot. And then they came again the next day — I think it was the Lieutenant of Carabinieri. And other people came. The Italian Air Force. And also some experts, I don't

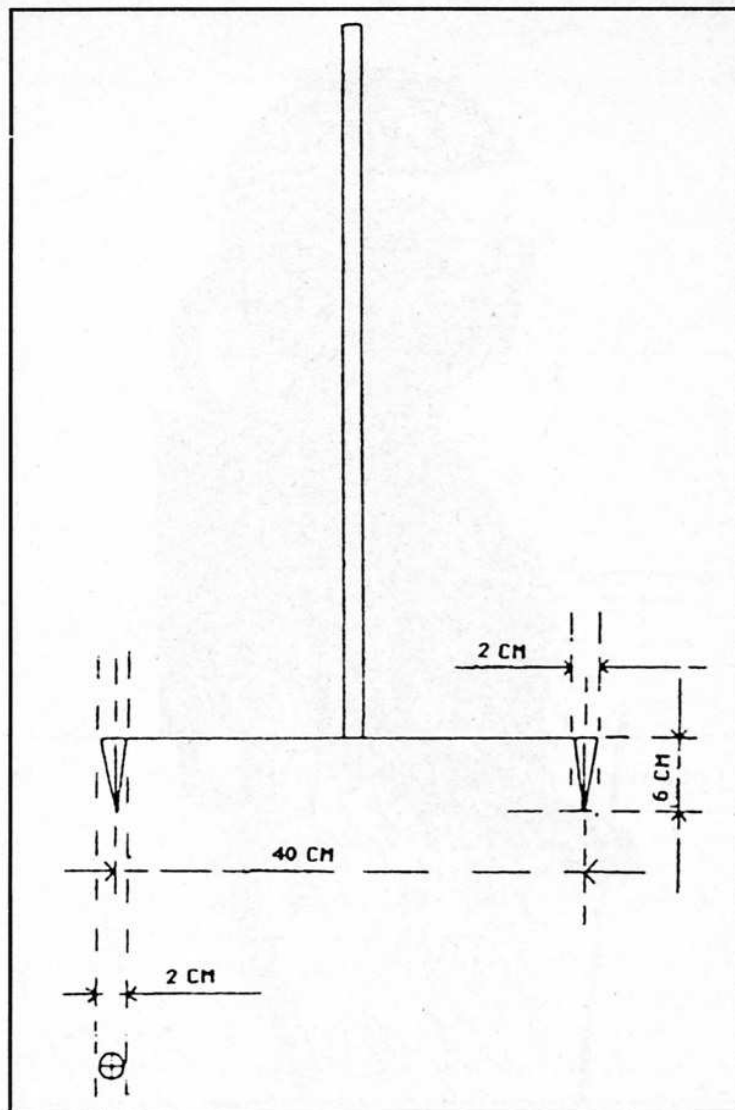

Fig. 3 The forked rod.

know exactly who. That's all I saw.

Q: Thanks, Don Peppino!

(Tape-recorded interview, transcribed by Umberto Telarico.)

A RECONSTITUTION OF THE FACTS OF THE CASE

ON the morning of Monday, October 8, 1984, Signor Giuseppe Coccozza, a 57-year-old Italian farmer, was alone in his house, his wife and son having gone to the funeral of a relative.

At about 7.30 a.m., Signor Giuseppe decided to go to his field of alfalfa (lucerne), distance some 350 metres from the house, to get some fodder for his cow. He walks slowly — for he has arthritis in one leg — along a beaten-earth path flanking the limits of his property. At about 7.40 a.m., just after a bend in the path, he halts, for, ahead of him, and on the path, about twenty metres distant, he perceives an indi-

vidual of unusual appearance. (Fig. 1.) He is about 1 metre 20 cms. in height, is wearing something resembling a helmet on his head, round and of a dark colour. On his back he is carrying a rucksack — or box, about 30 cms. by 30 cms. in size, and of the same colour as the helmet; from the upper part of this rucksack or box a sort of tube runs up and joins the helmet at the nape of the neck. A second tube emerges from the lower side and seems to pass between the rucksack and the back of the entity.

The eyewitness estimates that the diameter of this "tube" was a little larger than the thickness of a finger

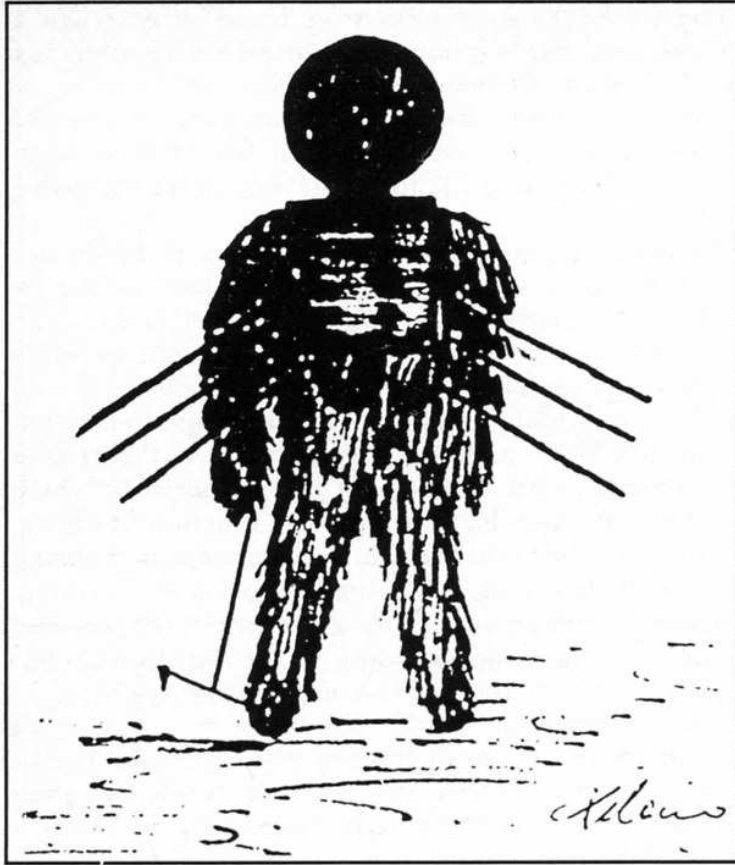

Fig. 4. The entity departs, emitting flames from his flanks.

(i.e. about 2 cms.). He also had the impression that there was a finer tube between the bulge observed at the place where the mouth would be and the upper side of the rucksack. However, this is not quite certain. (Fig. 2.) The rest of the body of the entity appears to be covered with a sort of hair (like that of a goat, according to the witness), of a dark brown colour, with long hairs some 10 cms. to 15 cms. in length. This personage appears to be engaged in exploring the ground with the aid of an instrument. This instrument is shaped like a reversed "T" with two points penetrating into the ground. (See Fig. 3.) Furthermore, Signor Coccozza observes that, as the individual is performing this "work", he raises his legs alternately, several times, as though intent on not getting too deeply embedded in the soil on the path, which is fairly soft and muddy due to stagnant puddles of water.

The eyewitness is greatly disturbed and alarmed by the presence of this stranger whom we have just described. His first thought is that it is a "madman in disguise". A few moments later, he tries to provoke some sort of reaction on the part of the individual: he coughs, hoping that his presence will induce the personage to depart. The latter, hearing the cough, halts and faces round towards Signor Coccozza, showing a sort of wide slit at the level of the eyes, of a bright aluminium colour. Then, a few moments later, he turns his back on the farmer and departs in the direction of a clearing among the hazel-bushes. As he walks, he

emits from both sides of him small bluish flames (like those of a blow-lamp) some 60-70 cms. in length. (See Fig. 4.) The emission of these flames is continuous and accompanied by a rhythmic sound (resembling the sound of an electrical apparatus). The witness, frightened, retreats and loses sight of the entity, which, after covering a distance of a few metres, vanishes behind a hazel-bush. About a minute later, Signor Giuseppe observes a strange flying object which rises into the sky following an inclined trajectory. The UFO appears to have taken off from the clump of hazel-bushes some 70 metres or so from the witness. In the space of a few seconds the strange craft climbs to 500 or 600 metres. Then, abruptly, it performs an acute-angled turn and heads towards the mountain range, seemingly towards the foot of them, as though with the intention of landing again. (Fig. 5.)

The witness describes the UFO as like a parallelepiped, or a "box" or "case" as he himself calls it, surmounted by a sort of "dish" supported by two tubular structures. (Fig. 6.) The flying object appeared to be of a dark brown colour. It emitted no perceptible sound or light. It is however to be noted that had there been any sound, if not very loud, it would have been blotted out by the noise of the river Sabato, flowing some 20 metres below the path, and only a few metres distant.

Signor Coccozza returns home, gets his shot-gun, and returns to the spot. Then he perceives numerous strange imprints like those of a long hoof (these are the marks left by the entity) and a number of holes spaced at regular intervals (these being the marks left by the rod carried by the entity). The witness follows up these traces as far as a clearing among the hazel-bushes, where he observes other marks, very clearly imprinted, which he connects with the presence of the flying object. Then he returns home again and awaits the arrival of his wife and his son Michele.

After the arrival of his family, he sends his son to the Carabinieri Station at Pratola Serra, to ask them to come. That same evening, the Carabinieri not having arrived, he sends a second son to request their help. Finally the Carabinieri do arrive and, after hearing Signor Coccozza's account, they go to inspect the marks (using electric torches). They return next morning with the Commanding Officer of Carabinieri at Mirabella Eclano, Signor G.S.F. Carrarelli, who takes charge of the necessary operations, namely preparation of a plan of the landing-site, detailed sketches of the trace-marks, plaster-moulds of same, and samples of soil and vegetation. That same day, the Carabinieri took Signor Giuseppe Coccozza to the Station at Pratola, where he signed a statement concerning the facts set out above.

Evaluation of the Case

The sole witness in this case, Signor Giuseppe Coccozza, a working farmer, is an individual who still

has all his physical and mental faculties, despite an operation for the removal of his gall-bladder eight months ago and arthritis in one leg. He appears to be a good observer, not at all emotional, who is difficult to impress, and mentally well balanced. (Incidentally, the operation undergone by him means that he is unable to drink alcohol.)

The description of the entity given by him is especially detailed, for, thinking he was dealing with a "disguised madman", he was not afraid, as is so generally the case when people experience phenomena of this kind.

As he has no electricity in his house, and the cost of having it laid on would be relatively high, Signor Cocozza possesses neither radio nor television. On the rare occasions when he has encountered talk of UFOs, it has been in the pages of the local weekly paper, *La Cronaca Vera*. In any case, he has always said he was sceptical on the matter of UFOs. This circumstance, together with his extremely modest cultural level, shows us that his story has not been influenced by any external factor, such as books, magazines, television, radio, etc.

Consequently, in our view there is nothing that might raise any doubts as to the credibility and good faith of Signor Giuseppe Cocozza

The Carabinieri from the Stations at Pratola Serra and Mirabella have expressed a similar view to this in their respective reports.

Should one desire at all costs to explain the UFO phenomenon at Prato di Principato Ultra in terms of the known, then the sole possible hypothesis is premeditated hoax, perpetrated by parties unknown, for

some equally unknown motive. In any case, such a hypothetical explanation could furnish no convincing answers to the following questions:—

1. Why choose to land at a distance of only a few metres from the trees, when it would have been more "normal" to land in the middle of the clearing?
2. Anyone organizing a "joke" of this sort would not have chosen so inaccessible a spot, half-hidden by trees. Furthermore, he would not have chosen to do it at a time of the day when people would so rarely be met, especially at that time of the year.
3. A very careful analysis of the marks apparently left by the UFO, and the irregularities in the terrain where they are, reveal that the supports on which the craft stood had not only the function of underpinning the craft but also the function of ensuring a well determined position vis-a-vis the ground, thus cancelling out the irregularities in the terrain.* The unknown perpetrators of the "joke" would in that case have included an aeronautical engineer.
4. What technique would have been required to lift (silently) a big parallelepiped (the UFO) to a height of 500-600 metres above the ground and then cause it to perform a right-angled turn and vanish over the mountains?
5. The "joke" would also have required the participation of a child in disguise (the entity). How long would the child have been able to keep the secret and not reveal the identities of the organizers of the prank?

Would it not have been "safer" to "disguise" an adult?

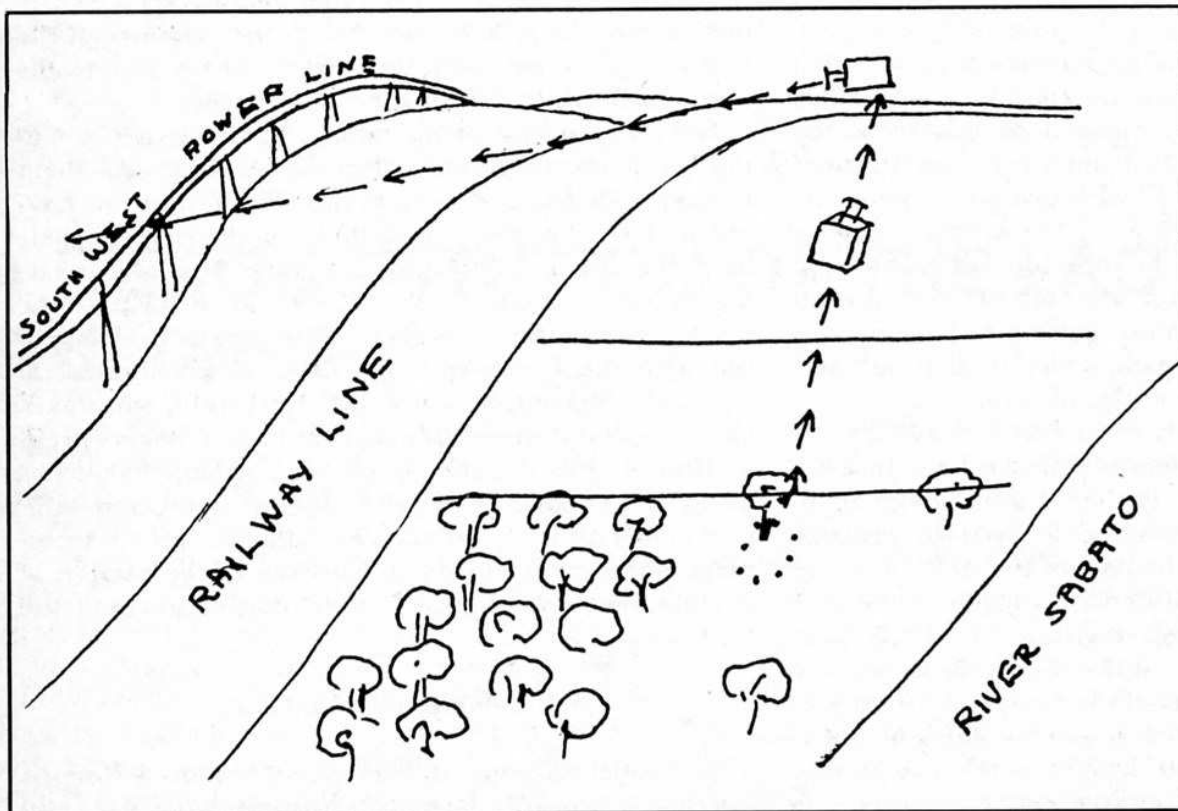

Fig. 5. The departure flight of the UFO.

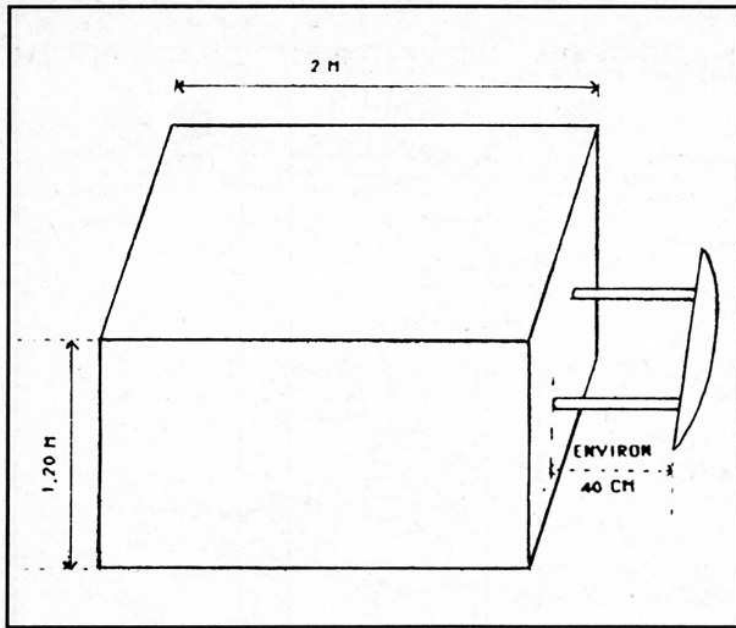

Fig. 6. The UFO, its size being estimated on the basis of the trace-marks.

Conclusions

There is then no reason to doubt the credibility of the testimony furnished by Signor Giuseppe Cocozza concerning this UFO phenomenon at Prato di Principato Ultra. This certitude is due not only to the objective verification of the greater part of the facts (which we are able to reconstitute thanks to the trace-marks left on the ground) but also due to the fact that, possessing neither a radio nor a television, the witness cannot have been influenced by Science-Fiction programmes.

There is consequently at present no reason for doubting that the events as related by the witness did in fact occur as he states. Furthermore, there is no indication whatsoever that might suggest a possible fraud.

Consequently our opinion, as investigators, is that a physical phenomenon of an unknown nature did indeed occur at Lapazzita (Commune of Prato di Principato Ultra) on October 8, 1984, and that it is at present not possible to explain it in habitual terminology. — Umberto Telarico

Analyses of Trace-Marks on the Ground

Radioactivity

Small quantities of soil and vegetation taken from the site of the presumed landing were tested with a Gamma-type radiation-detector of A.N.S.R. type manufactured by Abbotts.

These samples consisted of soil from outside the perimeter of the trace-marks (SAMPLE A); soil from inside the perimeter of the trace-marks (SAMPLE B);

and blades of grass from within the perimeter (SAMPLE C). The detector was adjusted for an energy field of between 15 and 70 Kilowatts, and the measurements — in counts per minute (CPM) — were taken twice.

The values obtained reached a maximum of 15 CPM for Sample B and a minimum of 2 CPM for Sample C. On the basis of this, the biologist who effected these tests, Mme Wanda Utech, concluded that, so far as the samples analyzed were concerned, any Gamma ray contamination could be ruled out, inasmuch as the minimal value when one is talking of contamination is 30 CPM.

A supplementary check effected with a Geiger Counter (for Gamma-type radiations) also yielded a negative result. This did not, however, rule out the possibility of contamination of the samples examined due to radiation of other than Gamma-type.

Number, Shapes, and Sizes of Trace-Marks

A. TRACES LEFT BY THE HUMANOID (Text extracted from the Report of the investigation by the Solaris Research Centre.)

1) The imprints found at the place where the witness saw the humanoid were scattered in a confused fashion within a 30-metre periphery. Starting from the tree situated near the path, they terminate at the spot where the "box" is presumed to have taken off.

These traces of the first type can be described as follows: an inverted cone with the point downwards, 12 cms. in diameter and 7 cms. deep. These marks were found especially at the spot where, according to the witness, the humanoid was "sounding" the soil.

2) A second type of trace-mark can be described as follows:— comparing it with the

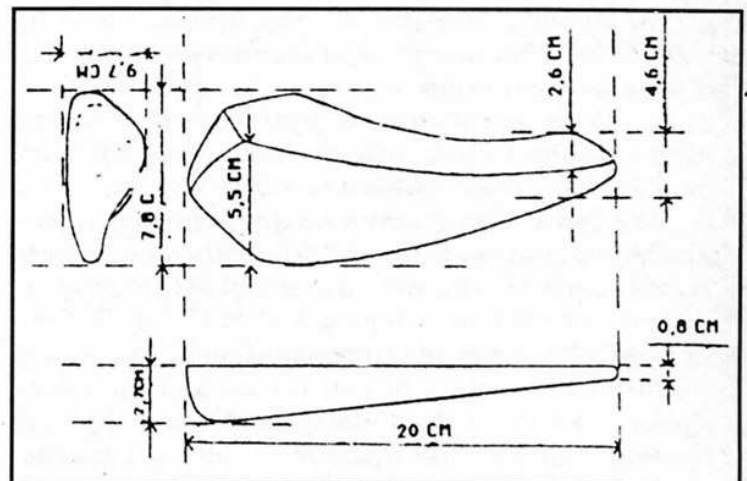

Fig. 7. Plaster-cast imprint of entity's right foot, at a spot 7m. from the landing site of the UFO.

imprint left by a human foot, we could say that, in place of the heel we find a groove resembling the hole made by a shoe-heel 2 cms. thick, and in the place of the sole of the foot, we observe two parallel plates. The total length is 20 cms. and the width 8 cms., and the depth certainly less than 2-3 cms. (See Fig.7.)

B. TRACES LEFT BY THE UFO (at a spot 35 m. to the north-west of the place where the witness saw the humanoid). (See Fig. 8.)

- 1) Two elliptical marks, 2.3 metres apart (See Nos. 4 and 8 on Fig. 8) and with the following dimensions: major axis: 20 cms.; minor axis: 10 cms.; depth: 8 cms.; surface: 191 cm². According to the investigation by the Solaris Centre, the "floors" of these two elliptical marks showed a series of grooves parallel to the minor axis.
- 2) Six roughly cylindrical holes terminating at the bottom in truncated cones, and disposed as shown in Fig. 8 (numbers 1, 2, 3, 5, 6, and 7). Their dimensions were as follows: maximum diameter (at surface): 9 cms.; minimum diameter (at bottom): 4.5 cms.; depth of the cylindrical portion: 2 cms.; depth of the truncated cone portion: 7 cms.; (thus giving a total depth of 9 cms., whereas the Solaris Centre gave them a depth of 20 cms. — could this difference be due to the deterioration in the condition of the marks during the time between the visits of the two parties of investigators?) The Solaris Centre's report also adds the detail that one of these holes looked as though it indicated the thread of a screw; total surface-area of six holes at ground-level: 63.5 cms².
- 3) The Solaris Research Centre alone mentions the existence of two parallel furrows, 2.30 m. long, 15 cms. wide, and 2 cms. deep, running from one of the elliptical marks to the other and flanked on the outside by the six conical holes.

With commendable caution, the Solaris Centre's report has the following comment on the trace-marks as a whole:

"We feel it is our duty to express certain reservations as regards the validity of the description of the marks, and notably as regards the shapes and dimensions of the conical holes; in fact, in view of the bad weather conditions prevailing during those days in that region and the enormous afflux of curiosity-seekers and "experts" right from the first hours after the sighting, the marks, or at any rate certain of them, could inadvertently have suffered changes before the investigators arrived."

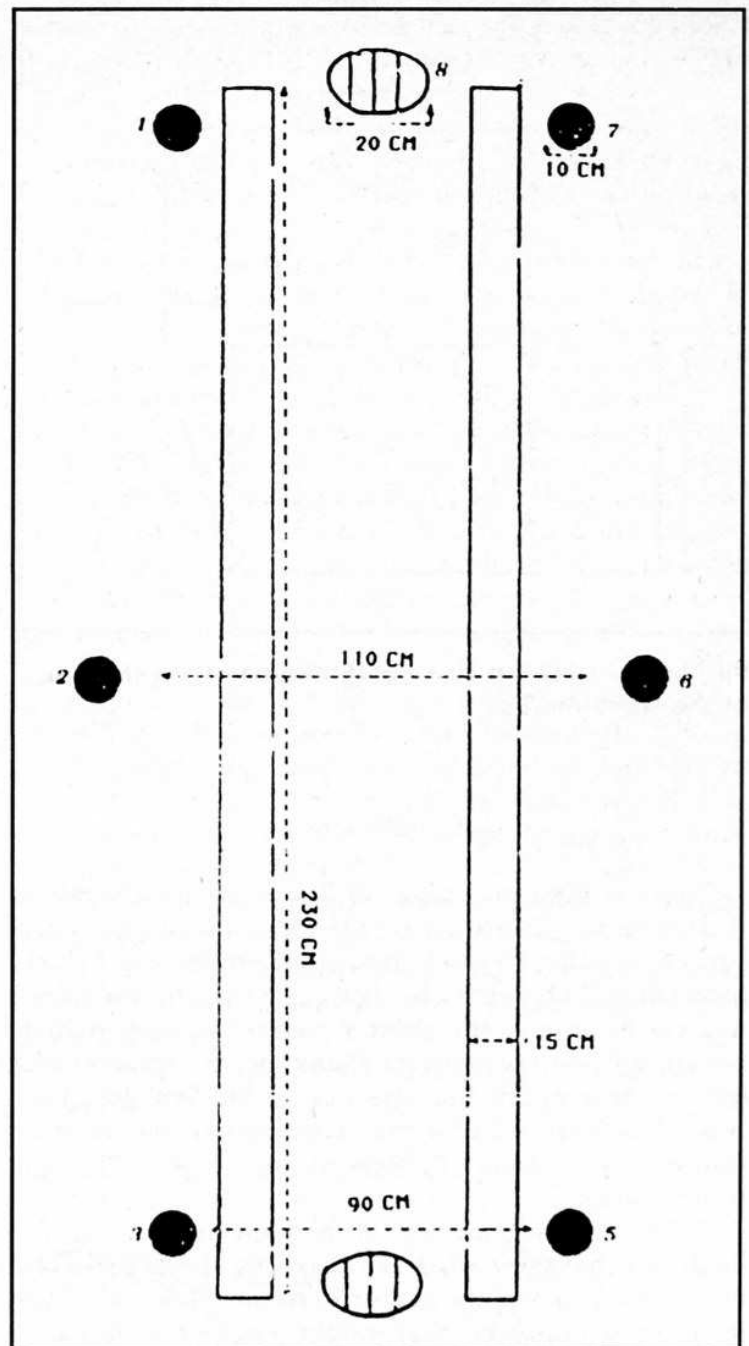

Fig. 8. The ground-marks left by the UFO (sketch by SOLARIS Research Group).

The two first types of mark, listed above under 1) and 2) and which are the only ones to present clear-cut depressions, yield a total support surface for the UFO of $(2 \times 191) + (6 \times 63.5) = 763$ cms².

The resistance of the soil to pressure was measured with a penetrometer. This instrument indicated a resistance (at the time when tested) of 1,25 kg./cm².

Applying the formula F (force-weight) = R (resistance of the soil) \times S (support surface), we obtain a pressure exercised on the soil by the UFO equal to $1.25 \times 763 = 953.75$ kgs.

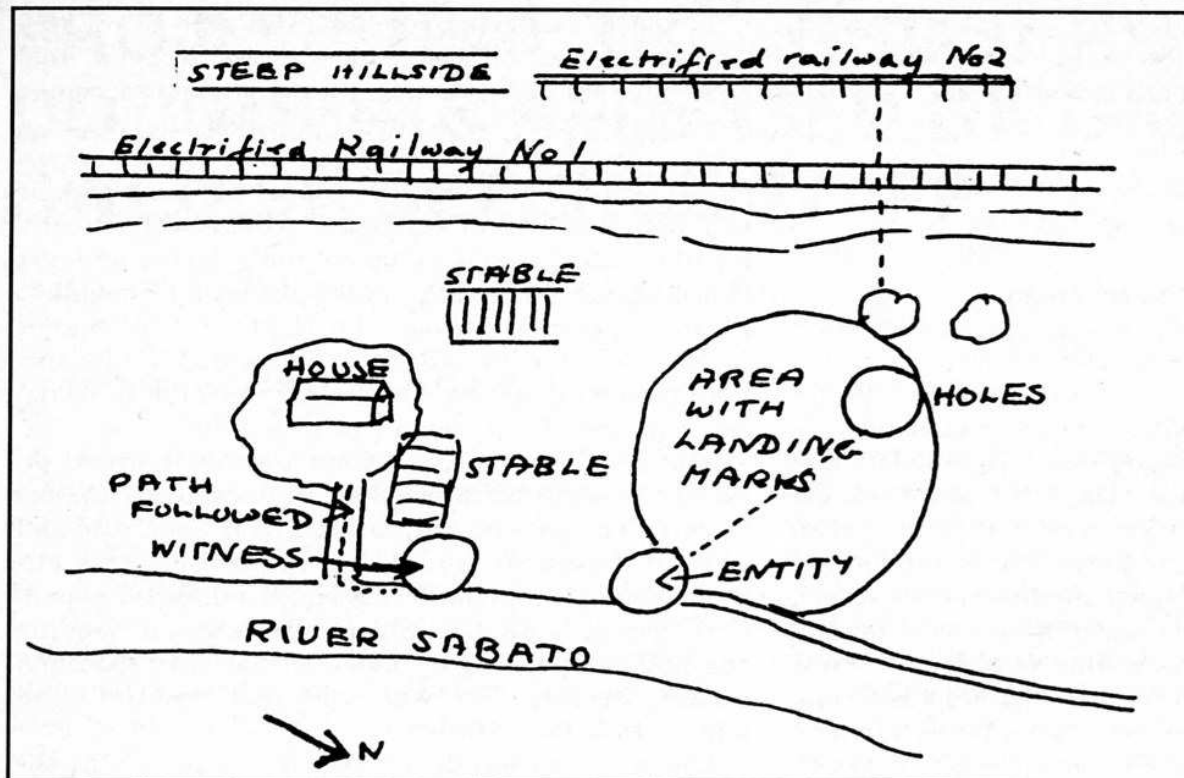

Fig. 9. General sketch of landing site. (Sketch by Solaris Research Group.)

Given the foregoing data, it will be noted that:—

- 1) The pressure exercised on the soil by the UFO would correspond to the real weight of that structure if the following conditions were met:
 - (A) The amount of movement of the UFO must have a value equal to or near to zero.
 - (B) The degree of humidity of the soil must remain constant during the two days following the event, since any variation would modify the degree of the resistance of the soil to deformation.
 - (C) The depth of the marks would have to be of only one centimetre.
- 2) The depth of the marks depends upon the speed at which the structure touches the ground (over and above its real weight and the degree of resistance of the soil). In the present case, examination of the marks permits us to affirm that they were produced by a body travelling at a speed very close to zero. In fact, were the contrary the case, the bulk of the marks would be at a deeper level than the surface-level of the terrain, which did not undergo pressure. This signified therefore that the pressure exercised on the soil by the UFO is in the vicinity of (in excess of) the real weight of the UFO itself.

- 3) Half of the pressure exercised on the soil by the UFO was on the surface of the two oval marks and half upon the total surface of the six cylindrical marks.
- 4) The fact that the marks are all of the same depth (9 cms.) suggests that the UFO landed from a position almost completely parallel to the surface of the ground.
- 5) The clear profile of the marks shows that the pressure which caused them was exercised from above downwards, perpendicularly to the surface of the ground.
- 6) The slight asymmetries observed in the disposition of the conico-cylindrical marks might possibly be explained — this is merely a hypothesis — by the fact that the supports were disposed in this fashion intentionally* (prior to the landing) in order to compensate for the asperities of the soil beneath. The undulating conformation of this perimeter (recorded by the investigators) confirms this hypothesis.

Temperature of the Soil

At 5.00 p.m. on October 8, 1984, measurements were taken of the temperatures inside and outside of the conico-cylindrical holes. This was carried out simultaneously, with two alcohol thermometers. The same test was repeated, under the same circumstances, at

4.00 p.m. on October 13, 1984.

The results obtained were:—

8/10/84 external temperature: 16.5 °C

8/10/84 internal temperature 18.5 °C

13/10/84 external temperature: 19.00 °C

13/10/84 internal temperature: 18.00 °C

Opinion of the Investigator

The abnormal increase in temperature inside the marks (measured at 5.00 p.m. on October 10, 1984, 57 hours after the UFO incident) could be explained — this is, of course, only a hypothesis — by the fact that the terrain situated beneath the UFO had been exposed to a certain type of energy of which a small amount still remained there in the soil in the form of infra-red rays. Three days after the first measurement, the temperature had descended again to a normal level (colder than the temperature outside the holes), which would seem to confirm the hypothesis as formulated above. This shows, in fact, that what we are here concerned with was indeed a transitory phenomenon that cannot be attributed to meteorological or geological causes.

Analyses of the Soil Samples

The purpose of the analyses made was to determine whether there might be any possible differences in the composition of the soil samples from the inside and from outside of the trace-holes. The spectrophotometric analysis was done with a Perkin-Elmer machine. In addition, a nuclear magnetic resonance analysis was also done, which revealed no traces of any type of protons.

Dr Corrado Malanga, of the University of Pisa, who conducted these measurements, concluded that “the analysis performed shows that the soil samples are perfectly comparable, within the limits of relative error of less than 5%, and display no bands indicating the presence of organic compounds; only mineral compounds are present”.

The pH measurements on all the samples gave a value of 5.5.

Note by Jacques Scornaux of L.D.L.N.

Complementary information extracted from the Report by the “Solaris” Research Centre, Naples.

As the independent investigations conducted by the Italian National UFO Research Centre (CUN) and by the “Solaris” Research Centre in Naples are largely in complete agreement, it would be tedious to reproduce both these reports *in extenso*. Apart from certain precise details about the trace-marks, we have extracted the few undermentioned items of additional information from the “Solaris” Centre’s report:—

As the “Solaris” investigation was the first one in

time, their representatives were still able to observe the state of fear in which the witness and his wife were. Signora Coccozza told them that she had come home and found her husband terrified, and both of them made it clear that they had never before seen a phenomenon of this sort. She added that some of their neighbours had said that, if the Coccozzas weren’t careful, the entity would come to their house and get them! She was thereupon plunged into a tremendous panic, especially during the nights. And Signor Coccozza told the investigators: “I’m scared lest he may have photographed me. I wouldn’t want him to recognize my face and come and carry me off!”

And at this point may I emphasise the harmful influence that can be inflicted on ill-informed witnesses by folk like this who only see the most simplistic and alarmist aspects of the UFO problem. And, as a further sociological detail of interest, I might here mention that, according to Signor Coccozza, the landing site has been visited by not less than one thousand curiosity-seekers. (So, who said that the UFOs no longer draw the crowds!)

One more curious detail, likewise mentioned by the witness, is that, after the Carabinieri, certain “experts” came from Naples and from Rome, with apparatus and instruments (for taking recordings, presumably) of kinds unknown to Signor Coccozza, which they introduced into the trace-holes. When they departed, he says they said that the trace-marks “*were the same as in other cases...*”

As regards the immediate environment, the Solaris report states that the Naples-Benevento railway-line passes at a distance of some 80 metres from Signor Coccozza’s house, and that three power-lines are just a few hundred metres distant.

The neighbourhood has a number of natural springs. There are few inhabitants in the area, and the site of the happenings is some hundreds of metres distant from the village and separated from it by sloping wooded terrains.

The UFO event caused no sensation, and has left no residue or after-effects. Signor Coccozza’s animals, fowls, rabbits, turkeys, geese, cattle, cats, and dogs (even one very aggressive watch-dog) all displayed no reactions.

Despite the fact that there are no other witnesses but Signor Coccozza, the “Solaris” UFO Research Centre in Naples are inclined, as are the investigators of the Italian National Centre, CUN, to favour the hypothesis that a close encounter of the third kind did genuinely occur at this spot.

Footnote

*For the discussion of precisely such a hypothetical type of retractable and adjustable landing-gear, see *The Landing at Socorro*, by W.T. Powers, in *THE HUMANOIDS*, edited by Charles Bowen (1969). — Editor, FSR

PROJECT 1946: THE "GHOST ROCKET" DOCUMENTS RELEASED BY THE SWEDISH DEFENCE STAFF

Anders Liljegren, FSR Consultant

Archives For UFO Research (AFU), P.O. Box 11027, S-600 11 Norrköping, Sweden

ALMOST exactly one year after the end of World War II a series of remarkable reports concerning unexplained aerial phenomena started to pour in to Swedish editorial offices and to the Defence Staff. During the May-December period of 1946 the Swedish defence headquarters received, according to official statistics, 997 such reports, but that figure is an underrating of the real number of sighting reports from Sweden and the Scandinavian countries during that year.

In about 100 incidents rocket-shaped objects — or luminous phenomena — were seen as they crashed towards the earth's surface. In many instances it seemed as if the phenomena were remote-controlled to crash into lakes and other water surfaces. Despite lengthy and extensive searches of the bottoms of several lakes the defence forces did not succeed in securing any metal, or similar wreckage parts, which with certainty could point to any kind of rocket construction. These new experiences were in sharp contrast to the territorial violations of the immediately preceding war years, when concrete evidence was secured through numerous airplane wreckages and other heaps of metallic scrap in several places.¹

"The ghost rockets" (or "ghost bombs"), as the phenomenon was christened by the media,² has for 40 years been an area of interest to UFO researchers, private citizens who try to investigate and document sightings of unidentified flying objects (UFOs). Lacking the support of the direct documents and observation data from this era, the phenomenon has been an object of wild speculation in books and magazines, not the least in the USA.

These writings have, of course, their background in a natural interest in what *really* happened over Sweden and Scandinavia in 1946. During 1947 reports of so-called "flying saucers" created an enormous sensation in the American press and finally forced the U.S. Air Force to start a more than 20 years long series of investigation projects. A search through 140 American newspapers has since revealed that the American sighting wave of 1947 had greater proportions than what was generally believed. For the summer months of June and July, alone, there are more than 850 sightings on file in American archives.³

There was a striking resemblance with the Swedish

phenomena a year before, although the two sighting waves described objects of completely different shapes. In both waves thousands of unprepared witnesses saw objects which neither they, nor their governments, could explain sufficiently. In Sweden, as well as in the United States, interest was primarily focussed on the Soviet Union, which was believed to be responsible for the strange occurrences. *Wild speculations on spaceships from other worlds were almost non-existent in those years (1946-48)*. Such theories were introduced during the summer of 1948 within the U.S. Air Force Project Sign and in the public media during 1949/50 through magazine articles and a book by aviation journalist *Donald E. Keyhoe*.

Swedish UFO researchers, who have attempted to locate the primary material from 1946, have been frustrated by statements from the Research Institute of National Defence and the Defence Staff that the documents were "lost" in the bureaucracy.⁴

Strong circumstantial evidence of secret documents

In 1976, thirty years after the incidents, an American researcher succeeded in finding some very interesting documents in the library of the Smithsonian Institution's National Air & Space Museum. Aviation and UFO historian *Don Berliner* was writing an article on the Swedish ghost rockets and made contact with the Museum to check their archives. Two important documents were found: one from the British Air Force Intelligence, the other from the Swedish Defence Staff...⁵

The British document, of five folio pages, is a detailed compilation and analysis of what British Intelligence had learned from Norway and Sweden. The SECRET British document takes a rather sceptical position regarding the phenomena. It was duplicated in at least 150 copies and distributed to British and American defence organisations. The distribution list points to a wide interest in the Swedish incidents. As early as 1958 the SECRET classification was cancelled by the U.S. Air Force, and the document ended up in the Smithsonian's open archives, where it probably remained for many years.⁶

Although the British report is interesting, *the Swedish document* is far more significant. It details the Swedish defence forces' own, direct experiences from

six months of investigations. It also gives clear and direct indications of the existence of a very comprehensive investigative file. The report was drafted within the Air Administration and the Defence Staff in December 1946 and sent as a letter to the Swedish Supreme Commander *Helge Jung* on the day before Christmas Eve. In September 1947 an English translation was made and sent to the USA via the Assistant Military Attaché in Stockholm, Lieutenant Colonel *S. H. Connelly*. The document had a main report of three pages plus seven appendices and also included the Swedish originals.⁷

It is reasonable to assume a connection with the investigations of "flying saucers" which had just started with the Air Material Command (the U.S. equivalent of the Swedish Air Administration) at Wright-Patterson Air Force Base in Ohio. It is probable that the Swedish report was communicated to the U.S. after a specific request from AMC and its Project Sign.

The world's first UFO investigation group?

What first becomes apparent from the Swedish document is that *Sweden was, as far as we know, the first country in the world to appoint a special committee — or delegation — to investigate phenomena of a UFO character.* This committee included representatives of the Defence Staff, the Air Administration, the Research Institute of National Defence (FDA), the Defence Radio Institute (FRA) and the Naval Administration. The Air Defence department of the Defence Staff collected all the reports from military and civilian sources. The committee's analytical work was co-ordinated mainly by employees of the Air Administration.

Chairman of the committee was Colonel *Bengt Jacobson*, head of the Material department of the Air Administration and directly subordinate to General *Nils Söderberg*, a legendary builder of the Swedish Air Force during the war years. Secretary and chief investigator was Air Engineer *Eric Malmberg* of the Material department's Equipment Bureau. Another regular participant at the committee meetings was Air Director *Henry Kjellson*, head of the Equipment Bureau, well known for his successful analysis of the remains of a V-2 that crashed in 1944 in south Sweden,¹ an analysis entirely confirmed by the British as they later took over the work. (Kjellson also became well known in UFO & Fortean circles for two of his books where he speculated on the possible use of advanced technologies by ancient civilizations).⁸

The committee was formed on July 10 and started immediately to analyze about 250 reports received concerning an aerial phenomenon at 14.30 hours on the day before. Up to July 8 about thirty other reports had reached the Defence Staff, mainly since a HQ order had been issued by the Staff on June 12 to all military units. Sightings were to be reported immediately according to a special form and sent to head-

quarters.⁹

The first, more substantial, sighting was made only three days after Gösta Carlsson had witnessed a landed disc-shaped object, and its occupants, in a glade near Vegeholm in south Sweden. "The next day I wrote a report to the Defence Staff, but I never sent it off. If I had they would have put me in a mental hospital," Carlsson revealed twenty-seven years later to a Swedish reporter.¹⁰

Without going into details it can be said that the Swedish document, discovered by Berliner, describes the committee's futile attempts to explain the mystery of the ghost rockets. Don Berliner published the document in an American magazine,⁵ despite information from the Swedish embassy in Washington that it was still considered SECRET in Sweden. In the United States, however, the document had only been classified CONFIDENTIAL. This low-rate classification was removed in June 1958. As late as in 1982 American researchers got the message, from Swedish authorities, that "portions of the documents dealing with witness reliability, radar trackings, and geographical plots, are still classified "secret".¹¹

The documents surface...

Berliner's article was cited in a German book and by UFO historian *Loren Gross*.¹¹ In this way the existence of the documents came to my attention. In August 1984 I wrote the Defence Staff. My theory was that 1,000 reports, or more, must be contained in at least 3 or 4 ordinary office files. The single file photographed in the Defence Staff offices in 1965¹² *could not possibly hold all of the rich material that Berliner's Swedish document spoke of!*

The Staff immediately confirmed that four volumes of secret documents concerning "space projectiles" (as the project was coined) had been retrieved. The documents surfaced at the Staff in May 1983, when old documents were re-evaluated for archival purposes.

We — the author, and *Clas Svahn*, a north-Swedish journalist — have now had the opportunity to work with these documents for almost two years. There is still a certain amount of secrecy that surrounds them, but this has been no obstacle to us since I had a previous permission from the Swedish Secretary of War to view similar secret documents on the 1930s ghost-flier phenomena. It has even been possible to make copies of about 1,000 pages.

Archives for UFO Research has been permitted to publish the documents, the secrets of which are of very little *military* significance after 40 years... The intention is first, however, to supplement the Defence Staff archives on a number of points. Some thirty Swedish newspapers have been checked. Witnesses who experienced sightings are contacted and interviewed. Often there are more details to uncover than what is immediately apparent from contemporary military investigations.



eVe

"She says a little girl from Orion gave it to her."

We also attempt to contact those people who took part in the committee's work and in the various military investigations. Our list covers some 50 names, but unfortunately several key persons are dead. In a few years' time we hope it will be possible to publish this unique material in detail, in Swedish first. There is also a great interest, from foreign researchers, to know the true facts about the ghost rocket phenomenon.

Can "the ghost rockets" be explained?

The only theory seriously considered by the Swedish committee — apart from astronomical and known technological solutions to subsets of the sighting data — was the possibility of *Russian rockets or remote-controlled weapons tests*. Through aerial, marine and radio reconnaissance against the southern and eastern shores of the Baltic it was attempted to determine if the Soviet Union — aided by German technicians — was developing V1 guided planes or V2 rockets. Some intelligence measures were of such a kind that first they had to be authorised by the Government. In spite of this, there were no results that could solve the riddle.

In the historical perspective one decisive argument

against the V-weapon theory is that the German weapons, at the end of the War, had an upper range of between 300 and 370 kilometres.¹³ When Allied troops marched through France, Belgium and Holland it was no longer possible to use V-weapons against Britain due to their limited range.

In Sweden clearly metallic "ghost rockets", with spool-shaped bodies and often small fins, were seen on at least 225 different occasions during 1946 (according to statistics from the Defence Staff).⁷ Sometimes they came from the south and dived into northern lakes such as Storsjön and Kölmjärv, at a distance of 1000-1500 kilometres from the north-German coast. Even considering *Esthonia* as their point of origin, well-observed and documented crashes — like the one in Lake Kölmjärv¹⁴ — still means that the Russians, during one single post-war year (when great parts of central and eastern Europe were in ruins...), would have succeeded in increasing the V-weapons range by three times.

It is known that the small number of knowledgeable rocket and aeronautical technicians which the Soviets had recruited, on October 22-23, 1946 were hastily deported from northern Germany to Moscow.¹⁵ In spite of this, "ghost rockets" continued to pass over Sweden, although in smaller numbers

than during the summer. *As far as we know, in the West, the first Soviet launch of a V2-rocket occurred only one year later, on October 30, 1947.*¹⁶

After all, theorizing on V2 rockets is really to distort the general sense impressions of the Swedish witnesses. "The ghost rockets" were mainly experienced as relatively slow-moving objects. "Airplane speed" is a standard phrase in the report archives of the Swedish Defence Staff. Witnesses on the shores of the lakes Storsjön, Kölmjärv and Mjösa had the time to clearly register small, rocket-shaped objects. In contrast to this it is a well-known fact that those V2s that hit London or Antwerp up to March 1945 did so at supersonic speeds. They hit ground at lightning speed, not giving nearby witnesses a chance to see their shape or details of them.

If we go on to speculate on a further development of the V1 missile plane, which in any case is a much more probable solution, we are still in difficulties. The V1s were surely simple and cheap to manufacture (about 1/10 the cost of a V2), but still the very number of Swedish reports is a puzzle. The Soviets — who else? — must have had an immense stock of missiles since reliable sightings of spool-shaped objects — often in full daylight — happened on at least 225 separate occasions, in Sweden alone.

In the report tables from the Defence Staff, used for their statistical analysis, it is only possible to find a chronological and geographical connection between two or more reports in a few cases. The sightings most often occurred *at widely separated spots and within several hours of each other*. This is a well-recognised pattern in UFO phenomena of today.

V1 missiles in such great numbers, sent over Sweden, would undoubtedly have left *at least a handful of scrap-heaps*, mainly in the south of Sweden. According to an official British investigation 8,070 V1s were aimed at London. 7,488 reached the English coast, then anti-aircraft defence and fighters brought down 3,957. Only 2,420 reached their target area. Thus at least 1,500 missiles crashed along the way due to *functional disturbances in the plane*.¹⁷

Walter Dornberger, head of the Peenemünde base where V1 and V2 were developed, reports in his book an even greater rate of failure: 3,300 out of 9,300 V1s didn't even reach the English coast before they crashed.¹⁸

Finally: *Why take the risk of testing an experimental missile (which is implied by the dramatically increased action range) over neutral Sweden*, when the Soviet Union had vast deserted areas which, undoubtedly, would be more suitable? Such a series of tests must have been foolhardy in view of the risk of discovery through scrap on the ground.

The proceedings of the Swedish committee's meetings clearly mirror the bewilderment of these military investigators. Participators in this work were the chemical laboratories of the FDA's section I, led by professor *Gustaf Ljunggren*. *Some 30 fragments and*

other remains were analyzed by them, but nothing was found that even remotely resembled the remains of a metallic rocket or missile. In most cases, instead, the analysis pointed to lumps of slag that were surprisingly similar. It is striking that this slag was found in so many places with parts of vegetation melted into the lumps. This phenomenon made the FDA chemists suspect the lumps had been on the ground for a long time, a theory contradicted by the eyewitnesses' reports. The few minor remains of metallic objects FDA investigated could be given reasonable explanations without taking rockets or missiles into account.

Radio interception and direction-finding was arranged by FRA, the then newborn Defence Radio Institute, from specially equipped B18 bombers flying over the Baltic. Suspicious transmissions were intercepted. In some cases the broadcasts are similar to those that had directed the radio-guided versions of the V1, but it was not often that these transmissions were intercepted simultaneously to reported visual sightings.

Radar stations of the Air Force and coast artillery corps caught clear echoes on a number of occasions. In one case there was a simultaneous visual sighting of a luminous phenomenon. Liaison between radar and fighter airplanes was not very effective in the Swedish Air Force in those days. In the autumn of 1946 there were attempts, however, to create such a defence organisation in the Stockholm area but the rockets never appeared, or were observed when radar and fighters were on non-alert.

Project 1946

The project to collect, analyze and compile data on the 1946 incidents will continue during the coming years, and includes the following sub-projects:

1. *To locate and interview witnesses who had sightings in 1946*. A number of the most interesting cases have already been investigated, but there is still much work to be done. We invite anyone who knows about sightings from 1946, or from the war years 1939-45, to contact us.
2. *Trace and interview members of the "ghost rocket" committee*. Biographies are collected and members who are still alive are contacted for interviews.
3. *Complete the coverage of the press*. Some 30 Swedish newspapers have been combed for reports, articles, editorials. In total there were 230 Swedish dailies in 1946, so there is still a potential for new discoveries particularly concerning local reports that often did not reach the Defence Staff in Stockholm.
4. *Computer catalogue and analysis of as many reports as possible*. In total the primary data now comprise between 1,500 and 2,000 incidents. The reports are catalogued in a report file, SCANCAT. SCANCAT is intended for statistical tests and information retrieval. In the end it is expected that this file will also contain the 1930s ghost flier reports and post-

1946 reports from Sweden and Scandinavia. The file is built in a Victor 15 Mbyte IBM compatible personal computer with dBase III, a standard database program. One of the long-term goals of the project is to facilitate comparisons between different "age sets" of UFO data such as ghost fliers compared to ghost rockets. We also intend to make statistical studies of the flight directions of aerial phenomena in 1946 and during the 1930s era to see whether these data fit the Soviet or German theories of these sighting waves.

5. *Further research in the Swedish archives.* Many chains of events during the military investigations must be clarified through continued research in other files at the War Archives, the National Archives and the FDA archives. For instance, a study of the secret Swedish Air Force file on crashing aircraft has shown that a rumour that an air crash on August 12, 1946 was caused by collision with a "ghost rocket" has no truth to it.

6. *To document the intelligence interest in the ghost rockets.* As stated before, documents from British and American intelligence sources show a certain interest from the main powers. There were high-level contacts between Swedish military and allied intelligence people who, during World War II must have had an intimate knowledge of reports on "foo fighters". *James Forrestal, the American Secretary of the Navy, suddenly arrived in Stockholm to see the Swedish Secretary of War, just one week after the ghost rocket committee was formed. The Defence Staff answered written questions from one of the US attachés. A FBI document makes it clear that the American defence "exerted tremendous pressure on the Air Force Intelligence to conduct research and collect information in an effort to identify these sightings."*¹⁹

A newly released document mentions no less than 44 different documents on the ghost rockets in the archives of the U.S. Air Force. Unfortunately it will not be possible to see these documents since a cross-reference file has been lost while transferring records to the American National Archives.²⁰

7. *To document what happened in Sweden during the war years.* Between 1940 and 1945 Sweden organised the greatest aerial surveillance in its history. From hundreds of places there was a continuous look-out for alien aircraft. About 16,000 intruding aircraft and objects were catalogued in the defence files, but 5,890 objects still remain as "not identified".²¹ Are there any reports with UFO characteristics in this file? In any case we know, from the press, that "ghost rockets" were sighted in the north of Sweden as early as 1939.

There are also clear indications of strange objects violating Swedish territory during the winter 1944/45. In January 1945 there were diplomatic protests in Berlin against the observed overflights of a new kind of weapon, nick-named V3 by Swedish sources.²² Some aspects of these violations

seemingly do not match with modern knowledge of German V-weapon technology.

We are also taking note of all foreign sightings during the 1939-46 period found in the international literature. *For example, on May 27, 1943 the crew of a British bomber watched a cylindrical, silvery object hovering over an allied bomber fleet of 400 planes as they were attacking Essen.*²³

8. *What has been published about "the ghost rockets" since 1946?* The phenomenon is mentioned by each and every UFO-author during the 40 years that have passed. The ghost rockets were used as an argument for possible as well as impossible theories. Through literature studies in the AFU library, one of the most comprehensive UFO libraries in the world, we try to map this aspect. We are also tracing parallel cases to the 1946 incidents, trying to document that these strange missiles are a continuing phenomenon.

If you have any information on the incidents of 1946, and investigations during that year, or the preceding war years, we would appreciate a word from you to:

- Anders Liljegren*, P.O. Box 11027, S-600 11 Norrköping, Sweden. Telephone +46 11 14 46 50 (home phone).
- Clas Svahn*, Mjöluddsvägen 97, S-951 57 Luleå, Sweden. Telephone +46920 279 53 (home phone).

NOTES AND REFERENCES

1. For example the V2 crash at Bäckebo in south Sweden on June 13, 1944. The remains were turned over to the British after a very thorough investigation by Swedish Air Force scientists, who exposed the new German technology before the Allies. (The Swedish scientists and experts who took part in the investigation were the same as those who formed the nucleus of the 1946 ghost rocket committee).
2. In certain works the terms "ghost airplanes" and "ghost fliers" have, unfortunately, been used for the 1946 phenomenon, causing some misunderstandings. The term "ghost flier" should — in our opinion — only be used for airplane-like objects, e.g. those *airplanes* reported from northern Scandinavia during 1933-37 and in the mid-1970s from the county of Värmland in western Sweden. Surely a *small part* of the 1946 phenomena were observed as "ghost planes" (looking like airplanes or birds), but the overall majority of 1946 sightings concerned rocket-, torpedo-, and cigar-shaped objects with little resemblance to conventional airplanes.
3. *Ted Bloecher*: Report on the UFO wave of 1947. The author, 1967. About 200pp. Contains case descriptions from the press, from the U.S. Air Force and from the files of private UFO organisations. A detailed account of 1947 is also found in: *Loren Gross*: UFOs: a history, Vol. 1: July 1947-December 1948. Arcturus Book Service, 1982, about 170 pages.
4. *K.Gösta Rehn*: Nya fakta om de flygande tefaten. Zindermans, 1969, page 50, plus a number of other Swedish books and articles.

5. *Don Berliner*: The ghost rockets of Sweden. Official UFO, October 1976, pp. 30-31 and 60-64. Also correspondence with Berliner, 1985.
6. *A.I.2 (g)*: Paper 271/46: Investigations of missile activity over Scandinavia. 9th September, 1946.
7. Intelligence Report R 63C-47. 24 September 1947, includes "Summary of Letter to Commander in Chief, 23 December 1946".
8. *Henry Kjellson*: Forntidens teknik, Nybloms, original edition 1956; Forsvunnen teknik, Nybloms, original edition 1961.
9. Försvarsstaben, avd. L nr 7:49, June 12, 1946. (The Defence Staff, section L (air defence section).
10. *Fredrikson Sven-Olof*: The Ängelholm landing report. Flying Saucer Review, vol. 18, no.2 pp. 15-17. Also numerous reports and interviews in Swedish press and books on the same case.
11. *Loren Gross*: The mystery of the ghost rockets. Arcturus Book Service, 1982, second edition. Footnote on page 59.
12. *Jan Muhr*: Flygande tefat över Kumla! Article in the Swedish weekly Se, issue nr.35, 1965.
13. *Willy Ley*: Rockets, missiles and men in space. The Viking Press, New York, 1968, pp. 207 and 499. *Walter Dornberger*: V2 — Der Schuss ins Weltall, Bechtle Verlag, Gesslingen, 1952, p. 287.
14. *Clas Svahn & Anders Liljegren*: The Kölmjärv ghost rocket crash revisited. AFU Newsletter, 27, Jan-Dec. 1984, pp. 1-5.
15. *Werner von Braun and Frederick Ordway III*: History of rocketry and space travel. Thomas Y. Crowell, New York, 1975, p. 118. *MorgonTidningen* (Swedish daily), Oct. 23, 1946.
16. *Von Braun & Ordway*, p. 140.
17. *Ley*, p. 216.
18. *Dornberger*, p. 287.
19. *FBI*: Office Memorandum, from E.G. Fitch to D.M. Ladd, Aug. 19, 1947. In a volume of FBI/CIA documents on sale from Fund for UFO Research, P.O. Box 277, Mount Rainier, Maryland 20822, USA.
20. Letter from Lt. Colonel Douglas W. Eisemann, USAF headquarters, to "Project Sign", February 1948. In: U.S. Department of State documents on the Scandinavian ghost rocket phenomenon of 1946, published in 1985 by William L. Moore Publications, 4219 W. Olive St., Suite 247, Burbank, California 91505, USA.
21. Sveriges Militära Beredskap 1939-1945. Militärhistoriska förlaget, Stockholm, 1982, p. 538. (An official documentary on the Swedish military during World War II.)
22. *New York Times*, January 20, 1945.
23. *BUFORA Journal*, vol. 6, no.3, Sept/Oct 1977.

LIFE ON MARS, UFOs, SETI, SETA — AND SCIENTIST CLAIMS THE PARANORMAL IS FOR REAL!

Paul Whitehead, FSR Consultant

"Mars may be inhabited", announced an unexpected headline in a British national newspaper in July, a month which proved exciting in what some scientists had to tell us about extraterrestrials (and the search for extraterrestrial artifacts) and the paranormal.

It looked as if one sector of the scientific fraternity was going overboard in the search for ufonauts and their nuts-and-bolts craft.

The paper in question, *The Guardian* of July 22nd, didn't reveal who or what may inhabit Mars, but it did state the following:—"There may be life on Mars after all," two Americans claimed last night at a conference to mark 10 years of experiments since the first unmanned *Viking* space-craft landed on the planet in July 1976.

The biochemists, Gilbert Levin and Patricia Straat, said that no thesis had yet been able to explain the findings of an experiment which produced a "slightly better than 50-50 sign of living organisms, after radioactive organic chemicals were mixed with a sample of Martian soil to measure its metabolism."

Two days later, the *New Scientist* reported that Mars showed a range of distinctive signs of weathering by water or a similar liquid. Remote sensing of the planet from Earth had picked up features possibly caused by water flows (for example, rivers) and areas where water may have gathered.

The report concluded that there could be a huge volume of water locked up in the planet's crust — extending tens or hundreds of kilometres downwards from the surface area.

UFOs seen by "level-headed people"

A new book that appeared in the bookshops in July was "*A Dictionary of Space*," by physicist Dr Malcolm Smart, (Longman, £7.95). It was revealing in three of its entries.

First was its treatment of UFOs. While most sightings could be explained by natural or man-made phenomena, a number could not, he said. "Inexplicable sightings have been made by experienced and

level-headed people, e.g. *pilots and astronauts*.”

He ended the brief entry by stating: “There is no *technical* evidence that life forms exist elsewhere in the Universe.” (Did that mean there is *circumstantial* evidence — e.g., from alleged sightings of UFOs, or evidence of landings, etc? This is a question which FSR will try to follow up with Dr Smart — Ed.)

He then referred the reader to the sections of SETI and SETA, which were more bullish about alien civilisations.

SETI

Of SETI (*Search for Extraterrestrial Intelligence*), he said:— “Some astronomers think there could be *hundreds of thousands of advanced civilisations* in the Galaxy.” (Note: he is talking here of our galaxy alone, not the known Universe as a whole.)

“If life-forms exist, *we would expect to find alien probes*. It is quite possible that even a huge artificial alien habitat in the asteroid belt of our own solar system would be virtually indistinguishable from asteroids to terrestrial observers.

“*And for what reason would such a more advanced civilisation want to talk with human beings?*” he concluded.

SETA

Many readers may not have heard of the proposed SETA programme; I certainly had not. But SETA, Dr Smart tells us, stands for *Search for Extraterrestrial Artifacts*, and is a programme which has been proposed by a group of scientists who believe aliens may have visited — or are visiting — the environs of our planet.

The programme, he says, would “look for objects that would indicate the presence of *alien spacecraft* in the solar system. These objects might be beacons, robots or discarded debris from an alien search party, which were left behind on a planet or moon or in orbit and which, if discovered, would be of immense interest.”

(The question begs, has the push for this programme come from Dr Hynek’s “*Invisible College*”, claimed to be a group of scientists interested in the UFO phenomenon and the study thereof, who wish to remain anonymous, but who allegedly meet from time to time to discuss their findings?)

Nobel Prize Scientist supports Parapsychology

The Guardian came up with another surprise in July. Yes, there could be something to ESP, levitation, the paranormal and strange phenomena, an article told us. This time even the most sceptical reader had to take it seriously, for the writer was none other than Brian Josephson, Professor of Physics at the Univer-

sity of Cambridge! (And a Nobel Prize-winner! Editor.)

Invoking the fascinating world of quantum mechanics, he said only a small change in conditions might be sufficient for “*extraordinary phenomena*” to occur.

Pointing out that his own research involved quantum mechanics, he wrote:— “What quantum mechanics does show (and there are experiments to confirm this prediction) is that under certain circumstances a pair of particles cannot (in a way that can be properly defined mathematically) be thought of as being totally independent of each other, even when separated from each other by a great distance.” (See “*From Atoms to Tachyons and Hyperspace — And Back Again!*”, in FSR 31/1.)

Effects resulting from this could be produced in our own “normal” world, Prof Josephson said — and indeed they already have. He quoted, as one example, superconductivity, where a quantum effect involving just two electrons gets expanded “as a kind of chain reaction” to a macroscopic scale.

If the “quantum inseparability effect” could be expanded into our world, “the consequences would be something very much like ESP”.

“Likewise, with levitation, quantum mechanics predicts a definite non-classical force between two macroscopic objects.” He “knew of no reason” why an interaction between a human being and the Earth should not produce levitation of the person.

These extraordinary claims, made by a physicist at one of Britain’s leading universities, lends credence to recently-proposed theories that instantaneous communication — whether mental or by other means — over vast distances, may be possible, under the right conditions.

FOOTNOTE

In a sense, it could be argued that a clearer picture of the Universe we inhabit (and might be sharing with countless billions of other civilizations) has been emerging in recent months. Highly respected members of the scientific community (including astronomers) are coming out into the open and making statements which, only a few short years ago, would have invited ridicule from their colleagues.

At last, the study of the structure of the Universe and the forms of life it may contain has pushed the frontiers of scientific, philosophical and religious thought to new and exciting horizons.

Parallel with these developments is a perceptible acknowledgement from enlightened scientists and astronomers that the “story of the UFO” is far from written and over. Indeed, the quest to which *Flying Saucer Review* has long been committed, with assistance at times from both named and anonymous scientists, is now probably more “respectable” than ever before.

There is a new mood in the air; in the search for extraterrestrial intelligence, scientists are proposing spend-

ing millions of pounds on a massive telescope (with a 16-metre, or 52.5 ft. mirror), which will orbit the Earth at the turn of this century and try to "see" planets around nearby stars, according to the scientific journal *Nature* (week ending 24th July).

At the same time, physicists talk about parallel universes and multi-dimensions — even the possibility of ESP, of levitation, and of instantaneous (i.e. faster-than-light) communication!

There is also talk, from scientists, of 20 billion (i.e. 20,000,000,000) solar systems in our Galaxy alone, with maybe one in four supporting life as we know it, and perhaps one billion (1,000,000,000) advanced species all trying to communicate simultaneously.

The scientists even theorize, in a new book on Astronomy,¹ of all places, that a Master-Civilization may rule our Galaxy, maintaining dominance by preventing all other civilizations from talking to each other! And, according to this same book, *The Cambridge Atlas of Astronomy*, sceptics in the scientific community should be less blinkered, and take the study of UFOs more seriously!

COMMENT BY EDITOR, FSR

All indeed most splendid and encouraging stuff. The only thing that "bugs" us is this: why on earth is this sort of talk "all right" when it comes from scientists, including winners of Nobel Prizes, but most decidedly NOT "all right" when it comes from humble, non-scientific bods, like, for example, some of us at Flying Saucer Review who have been talking like this for years? (Can it be that, where wisdom is concerned, some are MORE EQUAL THAN OTHERS?)

Is it just another example of "the Big Battalions"?

Fuller details of these undeniably interesting theories will be published soon in FSR.

¹ THE CAMBRIDGE ATLAS OF ASTRONOMY (Cambridge University Press).

ALIENS, LASER BEAMS AND CLONES

Paul Whitehead, FSR Consultant

AN intriguing new theory of how advanced aliens might travel through Space was put to the recent meeting of the American Association for the Advancement of Science (AAAS), as reported in the British journal *New Scientist* of June 5, 1986. ("Beam Your Clones to the Stars.") They (the aliens) may have developed to the stage where they could produce electronic clones of themselves, said John Rather, vice-president of the Kaman Aerospace Institute.

These clones could even be self-replicating, allowing large numbers to "reproduce" by electronic means. "These people might then squirt themselves into Space on a laser beam," he declared. *In other words, they could travel in the form of light.*

Mr Rather apparently failed to acknowledge the role that Isaac Asimov, the scientist and science fiction writer, has taken in drawing up this theory.

In one of his non-fiction works, Asimov recently looked on future scientific developments, and how man could benefit from these. One of them was new ways of Space-travel; Asimov saw the possibility of man eventually being able to transform matter (e.g. a spacecraft) into photons (particles of light), and beam it into Space.

Time would not pass for any beings on board, Asimov wrote, because they would be travelling at the speed of light. They could cross millions or billions of

light years of Space in what to them would seem an instant.

In his speech, Rather stated that work on transmitting large amounts of data by laser beam was already well advanced. "The pace of development is such that there are definite possibilities for achieving data rates sufficient to transmit large numbers of the alien species," he said.

It was revealed that scientists want to scan the heavens for messages which may be transmitted by laser beams by advanced civilisations.

Lasers have the advantage over ordinary radio transmitters in that they can be aimed very accurately at a target — thus making better use of the transmitted energy, the Association heard.

Man might even send the genetic code for a "fully educated, functioning human being" in a laser beam!

During another lecture, delegates heard how man might one day use the solar wind from the Sun and other stars to power spacecraft up to half the speed of light.

Footnote:— Scientists have begun to consider means by which other civilizations might be attempting to communicate across Space. Radio or light waves may be two methods: gravitational waves or neutrino particles may be others.

MAIL BAG

Correspondents are asked to keep their letters short and give full name and address (not necessarily for publication). It is not always possible for the Editor to acknowledge every letter personally, so he takes this opportunity to thank all who write to him.

The "Swirled Rings"

Sir, — I would like to draw your attention to two very exciting research papers, by ROLL, W.G. *et al.* These are "The Miami Disturbances" (Journal of the American Society for Psychical Research, 65/409, 1971), and "Radial And Tangential Forces in the Miami Poltergeist", also in the Journal of the American S.P.R., (67/267, 1973).

Both these papers describe the exercise of a field of force associated with a young male "poltergeist". I quote:-

"The trajectory of objects in relation to his position were noted, and objects beyond a certain distance were unaffected, but objects close to him tended to make short, outward, *clockwise* movements to the right, while objects further away made longer *anticlockwise* movements. It was suggested that such effects are consistent with, and could be produced by, a cigar-shaped rotating beam of force."

These two papers should be read in conjunction with the article in FSR 31/5 (1986) by P. Delgado ("Mystery Swirled Rings in England").

As these swirls and rings are found all over our globe in clusters, one wonders what is the controlling mechanism, and why?

From my observations, it appears that a poltergeistic force is present normally in the universe, rather like gravity, and seems to be concentrated by a combination of geological formations or biological (human) objects.

This force is "all-pervading", like gravity, but, unlike gravity, it needs to be "concentrated" or focused in order to make itself felt. Then it appears to act rather like a combination of gravity and magnetism — moving any type of mass, and in any direction, or producing a tangential force when focused.

I am sure that further research will enable this force to be identified, studied, and harnessed — as "others" have

done with it.

Yours sincerely,

Bernard E. Finch, MRCS, LRCP, DCh.,

(FSR Consultant)

London NW11.

September 23, 1986.

"Flying Wings"

Dear Sir, — I always find FSR most interesting.

As regards "Flying Wings", these have been around for some time, so I was surprised to see them referred to as "futuristic".

The most successful probably were those in the USA by the Northrup Company in the 1940s. The U.S. Government contracted the XB-35 in September 1941. After several experimental machines had been built and flown, the first regular one was put into the air on June 25, 1946. It was powered by four engines and carried a crew of 15, so it must have been pretty big! The Company then went on to build an eight-jet-engined model (the YB-49). But I do not know whether these went into production for the U.S. Air Force.

Earlier still, back in the 1930s, "flying wings" had also been built in Russia and Germany. They were of course designed as bombers, but I do not know if they actually went into production.

In the late 1950s, the Armstrong-Whitworth Company of Britain built a research "flying wing" aircraft. It was a small single-seater (AW-52)*, powered by two jet engines, and was, I believe, flown in the Coventry area of England. However, this was not a true "flying wing" as the cockpit projected several feet in front of the wing.

There can be no doubt that many more "flying wings" were flown in other parts of the world, but came under the various governments' craze for Top Secret security! Probably Mrs. Richardson saw one of these. I do not

believe that the massive "flying wing" seen lately over New York State could have been one of these, however.

As a matter of interest, in 1945 (the last year of World War II) many people in Worcestershire (Central England) reported seeing an "illuminated cross" flying overhead at night. Remember that this was at the time of total 'black-out' regulations, and aircraft carried no lights except when taking off and landing.

In fact it was a *Beaufighter* fitted with special lights to enable radar scientists to calibrate their instruments fitted to radar-controlled searchlights and anti-aircraft guns! *I know*, because I was one of the 'target' pilots!

Good luck to you and your excellent magazine!

Yours truly,

A. Dimond,

Westbank, Longforgan,

Dundee, Scotland DD2 5EZ.

April 12, 1986.

*For details, now see FSR 31/4. — EDITOR.

Crescents, Delta-Wings and "Boomerangs"

Dear Mr. Creighton, — In FSR 31/3 you published my letter which briefly described a craft that I had seen in 1952/53. Subsequently I received a letter from Mr. D. Hampton suggesting that it was the AW-52. Since it clearly *wasn't* the AW-52, as it didn't fit the criteria I had described, I did not reply to his letter.

Now he has written to you (FSR 31/2, *Delta-Wings and "Boomerangs"*) saying he has solved the enigma, notwithstanding the fact that the information I had given was only very meagre. A man with his obvious talents should not have reached such a conclusion so readily with so little information!

As a matter of fact I endeavoured *many years ago* to resolve the enigma

myself, having heard about the AW-52, and having also consulted *Jane's All The World's Aircraft, 1948/49.*

Having now seen a picture of the AW-52 again in Mr. Hampton's article (it is *far too much* of a Delta-shape) I will reiterate for you a few points which I made previously, and add a few that I omitted before:

1. The machine was crescent-ovoid shaped.
2. No protuberances on the front.
3. No angles of any kind, no fins. Only curves.
4. Although of a differing shape, it was easily twice as big as the 'Meteor'.
5. No other aero engine was heard, apart from the engine of the accompanying 'Meteor'.
6. At least two other people saw the craft.
7. It was *not* the AW-52.

As an ordinary country person myself, I have found such people very observant of what goes on around them; some are even quite intelligent.

I enclose a sketch of what I saw. (It was of course flying on a horizontal plane — not 'on edge' as I have drawn it here).



Yours sincerely,
Mrs. Joan Richardson,
 Orchard Cottage,
 Cooper's Lane,
 Bramley,
 Basingstoke, Hants.
 June 8, 1986.

**Two "Boomerangs" Seen
 Seven Years Ago**

Dear Mr. Creighton, — With reference to the "Boomerang" referred to in FSR 30/3 and 34/3, I just want to say that I have seen two very similarly-shaped objects in the night sky seven years ago, in the summer of 1979.

I was walking along a dark path with a friend on the warm, summer night. Everything seemed perfectly still and calm. The time must have been about 8.00 p.m.

For some reason, I looked up at the sky, and noticed two objects just sailing across without a perceptible sound. I told my friend to look, so that we both saw the same thing. We both strained our ears to hear any sound,

but could hear none. So we just continued watching them sail off until we could no longer see them. The sighting must have lasted five minutes or so at the most, and during that time nothing about their appearance or motion showed any change. They kept the same speed all the time.

My impression was that they would have possibly been of the same size as a "Jumbo" jet, but then of course I was unable to judge how high they were. I am merely guessing, and, for all I know, they might have been huge!

The night was almost clear, between clouds, so outlines were visible. There were no street-lights or other lights around us.

This all took place over a country area of Barnet, Hertfordshire.

As I stood and watched them, I had no feelings of fear or excitement, and in fact I have not thought much about the sighting up till now, until the "Boomerang" reports jogged my memory. I always thought that seeing something like this would never be forgotten. Strange how I had almost forgotten it completely until now!

**RED, WHITE AND
 GREENY BLUE LIGHTS**

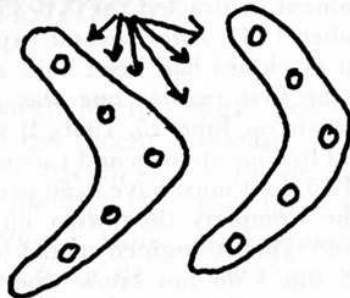

**MOVING IN THIS DIRECTION
 TOWARDS THE NORTH**

Yours faithfully,
 (Miss) J.B. Bodimead,
 32 Becmead Avenue,
 London SW16 1UQ.
 June, 1986.

**On Quantum Physics and Time,
 Velikovsky, etc.**

Dear Mr Creighton, — I enjoyed your reprinted article, "UFOs and the Fourth Dimension", by Luis Schönherr in FSR 31/1. I had come to about the same conclusions myself after initially becoming interested in the UFO Phenomenon about 1964 or 1965.

But, of course, "time travel" leads to many paradoxes which lie beyond the

understanding of Twentieth Century Science. These mind-bending puzzles were dealt with in the May 1974 issue of "Scientific American" by Martin Gardner in his "Mathematical Games" department.

In that article he mentioned that scientist Richard P. Feynman had received the Nobel Prize in 1965 for his mathematical demonstration that anti-particles in certain nuclear reactions *actually do momentarily move into the past!*

Nevertheless, if some science in the future of the Earth ever were to learn the secret of backward time-travel, as in H.G. Wells' "The Time Machine", it would lead to a paradox. That science would be in danger of dissolving itself out of existence!

If transportation of physical matter across Time is possible even momentarily, and in a nuclear reaction, then it is not beyond the realm of possibility that some hyper-science millions of years in the future will eventually develop craft which we should see appearing and disappearing in our skies. The occupants of these craft would certainly not want to disturb the general flow of events in the Past — the ancient history upon which their own civilization continued to rest. This might seem to offer at least one explanation of the phenomena — although, as Mr Schönherr states, others could come from anywhere in the Universe — and at or from any time in the history of the Universe, past, present, or future.

But there are several points that I would like to get across to the readers of the FSR, which would be of equal importance and which would follow this line of reasoning:—

1. If a science gained the power of altering the Past, it would give that science the ability to create and destroy entire civilizations.
2. *If the UFOs represented such a science, their occupants would use every means at their disposal to confuse and censor any investigations of their activities. And this indeed does seem to be the case. Certainly Dr J. Allen Hynek has described a strange affectation of many mature scientists when confronted with the subject of the UFOs. They became "different personalities" — but on that one subject alone. And this censorship has been successful! Many, if not MOST, people are now beginning to believe that UFOs don't exist. The news media, as Dr Hynek said,*

just will not print most of the UFO reports, and often deliberately distort those that they do carry, in order, obviously, to make them sound preposterous.

3. But most intriguing of all is the discovery I have made that there is the story of a War, fought across Time, for the ultimate control of the Earth, that story being contained in that ancient, Pyramid-like enigma, the *Bible*.

However, because of the numerous religious dogmas and creeds, and vociferous zealots haranguing us on their own particular interpretations — zealots who only too often discredit themselves badly by their own actions — the true story of that War seems never to have been understood by men.

4. During that War, it seems that, the entire Earth — so the *Bible* claims — was moved into a new orbit in the Past! This dissolved countless civilizations already existing in the Future as the changes swept forward in Time. They were kept alive as their Earth dissolved (only to reappear in a new orbit with a different population on it) in another form of existence. The Scriptures say it is in an “energized crystal!” You can call this science-fiction if you like, but the story is there — ignored by those who concentrate upon their own particular religious dogmas or creeds. *Could this be the purpose of religion — to confuse? — to control?*

One of the hundreds of references to this recreating of the Earth is contained in the 75th Psalm ... the earth and all its inhabitants are dissolved ... I said to the fools, don't do it” ... etc. It then goes on to predict a horrible punishment from the Lord. As I say, it *could* be religious science-fiction written over the thousands of years that it took for the works to be composed. And yet...

Dr Immanuel Velikovsky, M.D., a Princeton University professor and a personal friend of Albert Einstein, wrote a highly controversial book, *Worlds In Collision* (1950), which provided considerable corroborating evidence that the reference to the changes in the Earth's orbit several thousand years ago (mentioned in the Bible as part of the activities of the God of the Jews designed to protect his people from their enemies) really did take place.

But a very strange, inexplicable fog

of censorship and controversy has surrounded the book, the theory, and the author. Twenty-two years later, Warner Brothers published another book, “*Velikovsky Reconsidered*”, which gives an account of this weird campaign of censorship and suppression conducted by respected scientists, from which it can be seen that the whole thing was almost a “carbon copy” — if one can borrow this term — of the scientists' campaign of censorship and suppression against the UFOs.

Although, over the course of the years, many of Dr Velikovsky's predictions have in fact turned out to be correct, so far no scientific journal or scientific editor has given him the slightest credit.

Others simply claim his ideas as *their own*, and they get away with it. The story of Velikovsky himself is thus no less intriguing than the story of the UFO Phenomenon, and, indeed, *it seems to be simply a part of the same great enigma*.

If you like, I would be happy to write an article detailing both of these aspects and giving, as far as is possible, a neutral viewpoint about it all.

In FSR 30/6 you quoted a respected Muslim leader from Turkey who delivered a speech in London before others of his religion? He stated that the UFOs are operated by *Jinns* — who hold mankind in “enslavement”, deliberately causing all manner of wars and strife and disasters...”

I believe FSR could render a very great service to Western Civilization — and, indeed, to all Mankind — if it could get this point across to someone who might possibly be able to change the course of History ... which, as we observe it at present, with all the increasing acts of terrorism etc., social, and threats of war, not to mention incurable new plagues — is a gloomy picture indeed! The common denomination in the whole dilemma of our civilization is ... *confusion*.

If you would be willing to consider an article on the subject as suggested, I shall be happy to write it. On the other hand, if, as you once stated in a letter some time back, we are as it were a species of white mice in the hands of “this other Science”, then it probably wouldn't do any good, for there would be nothing that *we* can do to alter the course of History. We have been told that “the Truth” would free us. But that would be to assume that

we can first understand, and act...

Best wishes, and keep FSR afloat! I think it's there for a purpose.

Yours sincerely,
John D. Bailes, M.D.,
P.O. Box 685,
Gold Beach,
Oregon 97444,
U.S.A.
January 7, 1986.

“Out Like Light”

Dear Sir, — My parents, Barry and Barbara Walters, were on a motoring holiday near Loch Ness in Scotland recently when, at 4.30 a.m. July 3, as they were taking an over-night nap in a lay-by near Bogbain (some eight miles to the west of the north-eastern end of Loch Ness) they saw an enormous golden light stationary at about 35°-40° above the horizon. It seemed to make no sound, and the observation lasted for about five minutes. They calculated its diameter as about one-quarter of an inch at arm's length. So, while smaller than the Moon, it was much larger than a star.

My father decided to signal to it with his headlights, and gave three flashes, whereupon it vanished instantly, “just like a light going out”.

They waited for some time to see whether it returned, but it did not.

Yours faithfully,
Philip Walters,
400 Uttoxeter New Road,
Derby DE3 3HX.
July 8, 1986.

Lukewarm Response

Dear Sir, — FSR is something that I always receive with much pleasure, and indeed I look forward from one issue to the next.

Fascinating as I myself find the subject, I am surprised and disappointed at the lukewarm response in others when I suggest subscribing. — *Happy to borrow but not to buy!* It obviously does not strike such a chord of interest as it does with myself.

Yours sincerely,
P. M. Tustin,
27 King Edward Avenue,
Hastings,
East Sussex TN34 2NG.
October 22, 1986